

# FARBERWARE®

## SPECIAL SELECT



**USE & CARE INSTRUCTIONS**  
**10 CUP PROGRAMMABLE COFFEEMAKER**

**FSCM100**

# IMPORTANT SAFEGUARDS

When using electrical appliances, basic safety precautions should always be followed to reduce the risk of fire, electric shock, and/or injury to persons, including the following:

1. Read all instructions.
2. Do not touch hot surfaces. Use handles or knobs.
3. To protect against fire, electric shock, and injury to persons, do not immerse cord, plug, or Coffee Maker in water or other liquid.
4. Close supervision is necessary when any appliance is used by or near children.
5. Unplug from outlet when not in use and before cleaning. Allow to cool before putting on or taking off parts, and before cleaning the appliance.
6. Do not operate any appliance with a damaged cord or plug, or after the appliance malfunctions, or has been damaged in any manner. Contact Consumer Service.
7. The use of accessory attachments not recommended by the appliance manufacturer may result in fire, electric shock, or injury to persons.
8. Do not use outdoors.
9. Do not let cord hang over edge of table or counter, or touch hot surfaces.
10. Do not place on or near a hot gas or electric burner, or in a heated oven.
11. To disconnect, slide the **AUTO/OFF/ON** Switch to **OFF**, then remove plug from wall outlet.
12. Do not use appliance for other than intended use.
13. Be certain Lids are securely in place before operating appliance.
14. Scalding may occur if the Lid is removed during the brewing cycles.
15. This Carafe is designed for use with this Coffee Maker. It must never be used on a range top
16. Do not set a hot Carafe on a wet or cold surface.
17. Do not use a cracked Carafe or a Carafe having a loose or weakened handle.
18. Do not clean Carafe with cleansers, steel wool pads, or other abrasive material.

## SAVE THESE INSTRUCTIONS

**This product is for household use only.**

## **ADDITIONAL IMPORTANT SAFEGUARDS**

***WARNING: This appliance generates heat and escaping steam during use. Use proper precautions to prevent the risk of burns, fires, or other injury to persons or damage to property.***

1. Do not pour liquid other than water and the cleaning solution specified in this manual into the Water Reservoir.
2. Coffeemaker must be left to cool down for approximately 15 minutes before adding more water.
3. DO NOT attempt to move an appliance containing hot liquids. Allow appliance to cool completely before moving.
4. DO NOT leave empty Carafe on Warming Plate when appliance is turned **ON**, as the Carafe may crack or become otherwise damaged.
5. Always use fresh, cool water in your Coffeemaker. Warm water or other liquids, except as listed in cleaning section, may cause damage to the appliance.
6. DO NOT lift Water Reservoir Lid or Swing-Out Filter Basket until brewing is complete and all parts have cooled.
7. DO NOT put Carafe into a microwave.

***CAUTION: To prevent injury when utilizing Drip Stop Feature, replace Carafe within 20 seconds of removing during brewing process.***

## POLARIZED PLUG

This appliance has a **polarized plug** (one blade is wider than the other). To reduce the risk of electric shock, this plug is intended to fit into a polarized outlet only one way. If the plug does not fit fully in the outlet, reverse the plug. If it still does not fit, contact a qualified electrician. Do not attempt to modify the plug in any way.

## SHORT CORD INSTRUCTIONS

A short power-supply cord is provided to reduce the risk resulting from becoming entangled in or tripping over a longer cord.

Longer detachable power-supply cords or extension cords are available and may be used if care is exercised in their use.

If a longer detachable power-supply cord or extension cord is used, (1) the marked electrical rating of the cordset or extension cord should be at least as great as the electrical rating of the appliance, and (2) the cord should be arranged so that it will not drape over the counter top or table top where it can be pulled on by children or tripped over unintentionally.

## ELECTRIC POWER

If the electrical circuit is overloaded with other appliances, your appliance may not operate properly. It should be operated on a separate electrical circuit from other appliances.

This appliance is FOR HOUSEHOLD USE ONLY and may be plugged into any 120V AC electrical outlet. Do not use any other type of outlet.

# GETTING TO KNOW YOUR **FARBERWARE**<sup>®</sup> 10 CUP COFFEEMAKER

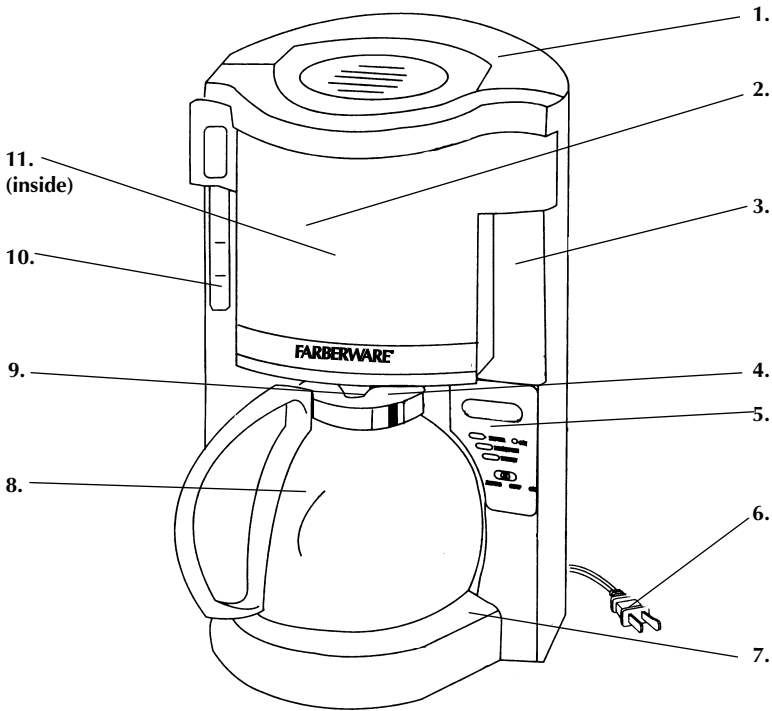

1. Water Reservoir Lid (P/N 30654)
2. Swing-Out Filter Basket (P/N 30651)
3. Water Reservoir
4. Carafe Lid (P/N 30652)
5. Control Panel
6. Polarized Plug
7. Warming Plate
8. Carafe w/Lid (P/N 30653)
9. Drip Stop Assembly (P/N 30781)
10. Water Level Indicator
11. Removable Filter Basket Assembly (P/N 30650)

# GETTING TO KNOW YOUR COFFEEMAKER *(Cont.)*

## **CONTROL PANEL**

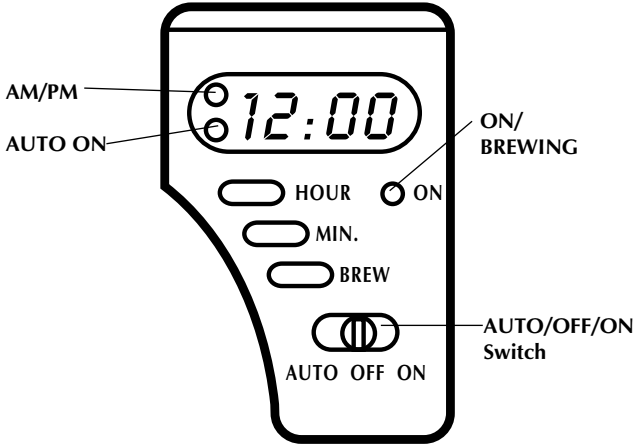

## **REMOVABLE FILTER BASKET**

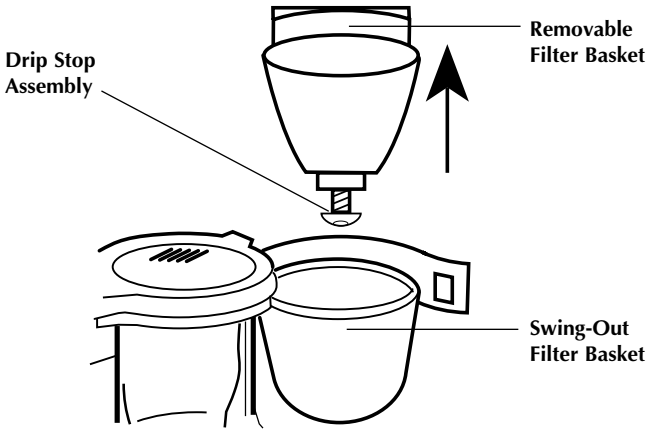

To remove the Removable Filter Basket for cleaning, pull Basket straight up and out of the machine. After cleaning, the Removable Filter Basket must be pushed all the way into the Swing-Out Filter Basket. Before use, make sure the Swing-Out Filter Basket fits securely back into the unit.

# INSTRUCTIONS FOR USE

## BEFORE BREWING COFFEE FOR THE FIRST TIME

**CAUTION:** *To protect against electric shock, do not submerge the Coffeemaker or allow AC cord to come into contact with water or other liquids.*

1. After carefully unpacking from carton, the inside of your Coffeemaker and Carafe must be cleaned.
2. Brew 10 cups of fresh water only. Follow the instructions under BREWING COFFEE Section but do not add coffee grounds to the paper filter.
3. When all the water has brewed into the Carafe, slide the **AUTO/OFF/ON** Switch to **OFF**.
4. Allow the Coffeemaker to cool for 10 minutes, discard the water from the Carafe, then repeat steps 2 and 3.
5. After the second pot of water has cooled, discard the water and thoroughly wash the Removable Filter Basket (see illustration on page 5), Carafe and Carafe Lid in warm, soapy water. Dry all parts thoroughly.

## FOR BEST RESULTS

We recommend using coffee which has been ground specifically for automatic drip coffeemakers. This type of coffee is prepared specifically for your Coffeemaker's brewing system and promotes fuller extraction to provide rich, full-bodied coffee.

Use only cone-shaped filters with this Coffeemaker. Cone-shaped paper filters are available locally at grocery stores. Use standard, #4 filters. You may also purchase permanent gold filters, which eliminate the need for disposable paper filters. Do not use basket-style paper filters.

## DRIP STOP FEATURE

This **FARBERWARE®** Coffeemaker has an Automatic Drip Stop Feature. During the brewing cycle, the Carafe can be removed to pour a cup of coffee from the Carafe. The Drip Stop Feature will prevent the Coffeemaker from continuing to brew coffee for up to one minute until the Carafe is returned to its proper position.

***IMPORTANT: The Carafe must be replaced on the Warming Plate, under the Filter Basket in less than a minute to prevent the Filter Basket from overflowing.***

## AUTOMATIC START-UP FEATURE

This **FARBERWARE®** Coffeemaker has an Automatic Start-Up feature. This feature allows you to pre-program the Coffeemaker to begin brewing coffee at a specific time. By leaving the **AUTO/OFF/ON** Switch in the **AUTO** position, the Coffeemaker will start-up automatically every day at the programmed start-up time. You may override the Automatic Start-Up feature at any time (without affecting the program) by sliding the **AUTO/OFF/ON** Switch to **ON**. To restore the program, slide the **AUTO/OFF/ON** Switch back to **AUTO**.

## AUTOMATIC SHUT-OFF FEATURE

The Automatic Shut-Off feature automatically turns off the Coffeemaker two hours after a programmed brew time. This prevents the Coffeemaker from being left on for an extended period of time, which is harmful to both the Coffeemaker and the Carafe.

***NOTE: The Automatic Shut-Off feature will only work when the Coffeemaker is in the AUTO position and a pre-programmed start-up time has been scheduled.***



# BREWING COFFEE IN YOUR FARBERWARE® 10 CUP PROGRAMMABLE COFFEEMAKER

**CAUTION:** Use this product with proper AC voltage rating only.  
Be sure to unplug the power cord when Coffeemaker is not in use for extended periods of time.

1. Lift the Carafe Lid. Fill the Carafe with cold water to the level for the desired number of cups (1-10). Open the Water Reservoir Lid, and pour the water from the Carafe into the Water Reservoir. Close the Water Reservoir Lid.

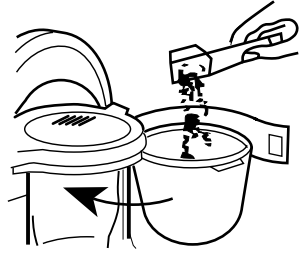

FIGURE 1

2. Swing out the Coffee Filter Basket and place a #4 paper coffee filter (or a permanent gold filter) inside the Removable Filter Basket.  
3. Put coffee grounds in the filter, using one level tablespoon of drip grind coffee for each cup of brewed coffee. (See Figure 1.)

4. Make sure the Removable Filter Basket is pushed all the way into the Swing-Out Filter Basket. Make sure the Swing-Out Filter Basket fits securely back into the unit.

**IMPORTANT:** When using the Timer feature, and at all times before brewing, remember to place Carafe on the Warming Plate.

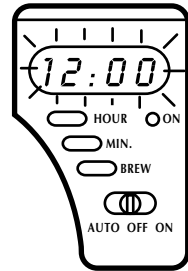

FIGURE 2

5. Place the Carafe on the Warming Plate, making sure the Carafe Lid is on the Carafe.  
6. Make sure the **AUTO/OFF/ON** Switch is in the **OFF** position. Plug the appliance into a standard 120V AC electrical outlet.  
7. The LCD will flash "12:00" until you set the time. (See Figure 2.)

# BREWING COFFEE *(Cont.)*

## SETTING THE CLOCK / TIMER

1. Set the Timer to the correct time of the day by pushing the **HOUR** Button until the correct hour appears on the LCD Display. Then push the **MIN.** Button to the current minutes. Be sure to note a.m. and p.m. times.

**NOTE:** *The LED in the upper-left corner of the Display indicates the P.M. hours.* (See Figure 3.)

2. To program the Coffeemaker for Automatic Start-Up, push and HOLD the **BREW** Button. While holding the **BREW** Button, push the **HOUR** Button to the desired start-up time hour. Continue to hold the **BREW** Button, and push the **MIN.** Button until the correct minutes appears. Be sure to note a.m. and p.m. times. (See Figure 4.)

**NOTE:** *Once the BREW button is released, the exact time of the day will be shown. To see the programmed start-up time, press the BREW Button.*

3. **To start the Coffeemaker immediately:**

Slide the **AUTO/OFF/ON** Button to the **ON** position. The **ON** LED will illuminate as the Coffeemaker begins brewing the coffee. (See Figure 5.)

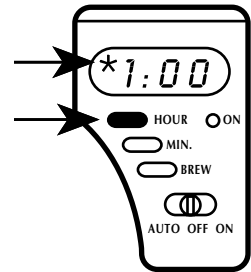

FIGURE 3  
AM/PM Indicator

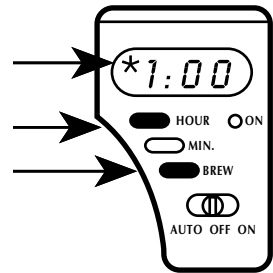

FIGURE 4  
Set Auto Start-Up times

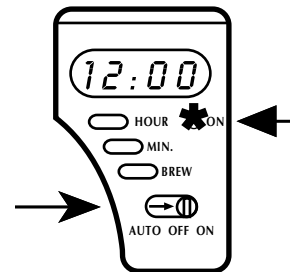

FIGURE 5  
Brew Coffee

## BREWING COFFEE *(Cont.)*

### 4. To set Coffeemaker to brew coffee using Automatic Start-Up feature:

Move the Slider to the **AUTO** position. The **ON** LED will turn off. The **AUTO** Indicator Light will illuminate. (See Figure 6.)

At the programmed time, the Coffeemaker turn itself on automatically. The **ON** LED will turn on as the Coffeemaker begins brewing and coffee will begin flowing into the Carafe.

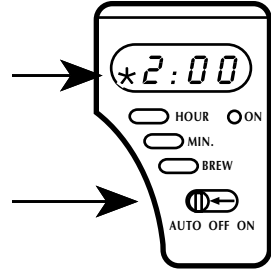

**FIGURE 6**  
Activate Auto Start-Up

***NOTE: The amount of coffee in the Carafe may be slightly less than the amount of water placed in the Water Reservoir, since some of the water is absorbed by the coffee grounds.***

5. To serve coffee, remove the Carafe from the Warming Plate. Always keep the Carafe Lid on the Carafe when pouring the coffee.

***IMPORTANT: When using the Drip Stop Feature while the Coffeemaker is still brewing, the Carafe must be replaced on the Warming Plate, under the Filter Basket in less than a minute to prevent the Filter Basket from overflowing.***

6. To keep the coffee hot, place the Carafe back on the Warming Plate when not serving.

## BREWING COFFEE *(Continued)*

7. To brew a second pot of coffee, turn the Coffeemaker off for 10 minutes and allow it to cool. Empty used coffee grounds and repeat steps for brewing coffee..

***CAUTION: Failure to allow Coffeemaker to cool may cause water to overheat and spray hot steam. The hot steam can cause severe burns.***

8. The Timer will automatically shut-off the appliance 2 hours after the switching on of the appliance to avoid wasting energy. If you want to have coffee at the same time the next day, move the Slider to the **OFF** and then to the **AUTO** position. By doing so, the next day the appliance will automatically switch **ON** at the programmed time.
9. To manually turn off the Coffeemaker, slide the **AUTO/OFF/ON** Switch to the **OFF** position. Also see AUTOMATIC SHUT-OFF FEATURE for more information.

# USER MAINTENANCE INSTRUCTIONS

## ***CARING FOR YOUR CARAFE***

A damaged Carafe may result in possible burns from hot liquid. To avoid breaking a Carafe:

1. Do not allow all liquid to evaporate from Carafe while on the Warming Plate. Do not heat Carafe when empty. If this happens, discard Carafe.
2. Discard Carafe if damaged in any manner. A chip or crack could result in breakage.
3. Never use abrasive scouring pads or cleansers as they will scratch and weaken the glass.
4. Do not place the Carafe on or near a hot gas or electric burner, in a heated oven, or in a microwave.
5. Avoid rough handling and sharp blows.

## ***CLEANING AFTER BREWING COFFEE***

***Note: Do not place anything other than water or the vinegar cleaning solution specified in this book into the Water Reservoir.***

1. To clean your Coffeemaker after brewing coffee, be sure the Coffeemaker is turned **OFF** and is cool. Discard the paper filter.
2. Wipe the outside of your Coffeemaker with soft, damp cloth and dry. Do not use abrasive soaps or scouring pads.
3. Hand wash Carafe and Lid in hot, sudsy water.

**DO NOT PLACE IN DISHWASHER.**

# MINERAL DEPOSITS AND DECALCIFYING

Your **FARBERWARE**® Coffeemaker must be cleaned when you begin to notice excessive steaming or the brewing time increases considerably. This condition is caused by a buildup of lime and mineral deposits from your water. If the pumping action stops before all the water has been pumped out of the machine, then the appliance requires decalcification.

The frequency of decalcification depends on the hardness of water used. The following table gives the suggested decalcification intervals:

## ***SUGGESTED DECALCIFICATION INTERVAL***

<b>Type of water</b>	<b>Frequency of decalcification</b>
Soft water	every 80 brewing cycles
Hard water	every 40 brewing cycles

## ***HOW TO DECALCIFY YOUR COFFEEMAKER***

1. Place a paper filter into the Removable Filter Basket. Make sure the Swing-Out Filter Basket fits securely back into the unit.
2. Pour one Carafe of undiluted white household vinegar into your Coffeemaker.
3. Place the empty Carafe on the Warming Plate and turn the Coffeemaker **ON**. When three cups have flowed through, turn the Coffeemaker **OFF** and let stand for 1/2 hour.
4. After 1/2 hour, pour the vinegar back into the Coffeemaker.
5. Place the empty Carafe on the Warming Plate. Turn the Coffeemaker **ON** and let all the vinegar flow through.
6. Discard the vinegar and the paper filter.
7. **To flush out all the traces of vinegar**, pour a Carafe full of tap water into the Coffeemaker. Turn it on, and allow it to cycle through.
8. Discard the water and turn the Coffeemaker **OFF**. Repeat steps 7 and 8.

## DECALCIFYING *(Cont.)*

### ***DECALCIFYING YOUR CARAFE***

Hard water can leave a whitish mineral deposit inside your Carafe. Coffee discolors these deposits, sometimes leaving a brownish stain inside the Carafe. To remove these stains, follow these simple steps:

1. Use a solution of equal parts white vinegar and hot water.
2. Let solution stand in Carafe for about 20 minutes and then discard.
3. Wash and rinse your Carafe thoroughly using a soft cloth. Do not use harsh abrasive cleaners. These may cause scratches which can lead to breakage.

# FARBERWARE®

## ONE-YEAR LIMITED WARRANTY

This FARBERWARE® product warranty extends to the original consumer purchaser of the product.

**Warranty Duration:** This product is warranted to the original consumer purchaser for a period of one (1) year from the original purchase date.

**Warranty Coverage:** This product is warranted against defective materials or workmanship. This warranty is void if the product has been damaged by accident, in shipment, unreasonable use, misuse, neglect, improper service, commercial use, repairs by unauthorized personnel or other causes not arising out of defects in materials or workmanship. This warranty is effective only if the product is purchased and operated in the USA, and does not extend to any units which have been used in violation of written instructions furnished by FARBERWARE®, or to units which have been altered or modified or to damage to products or parts thereof which have had the serial number removed, altered, defaced or rendered illegible.

**Warranty Disclaimers:** This warranty is in lieu of all warranties expressed or implied and no representative or person is authorized to assume for FARBERWARE® any other liability in connection with the sale of our products. There shall be no claims for defects or failure of performance or product failure under any theory of tort, contract or commercial law including, but not limited to, negligence, gross negligence, strict liability, breach of warranty and breach of contract. Some states do not allow the exclusion or limitations of implied warranties or consequential damages, so the above limitations or exclusions may not apply to you.

FARBERWARE® is not responsible or liable for indirect, special or consequential damages arising out of or in connections with the use or performance of the product or other damages with respect to loss of property, or loss of revenues or profit.

**Legal Remedies:** This warranty gives you specific legal rights, and you may also have other rights that vary from state to state.

**Warranty Performance:** During the above one-year warranty period, a product with a defect will be either repaired or replaced with a reconditioned comparable unit (at FARBERWARE®'s option) when the product is returned to the FARBERWARE® facility listed below. The repaired or replacement product will be in warranty for the balance of the one-year warranty period and an additional one-month period. No charge will be made for such repair or replacement.

### Service and Repair

If service is required, you should first call toll-free 1-888-881-8101 **between the hours of 8:00 am and 5:00 pm Central Standard Time** and ask for **CONSUMER SERVICE**. Please refer to Model FSCM100 when you call.

**In-Warranty Service** for a product covered under the warranty period, no charge is made for service and return postage. Please return the product insured, packaged with sufficient protection, and postage and insurance prepaid to the address listed below. Call for return authorization.

**Out-of-Warranty Service:** There will be charges rendered for repairs made to the product after the expiration of the aforesaid one (1) year warranty period, after purchaser is advised appropriately. Include \$8.00 (U.S.) for return shipping and handling.

FARBERWARE® cannot assume responsibility for loss or damage during incoming shipment. For your protection, carefully package the product for shipment and insure it with the carrier. Be sure to enclose the following items with your unit: any accessories related to your problem; your full return address and daytime phone number; a note describing the problem you experienced; **a copy of your sales receipt or other proof of purchase to determine warranty status.** C.O.D. shipments cannot be accepted.

Return the appliance to: ATTN: Repair Department, FARBERWARE®  
708 South Missouri Street, Macon, MO 63552

Any questions or comments can be directed to Salton, Inc. at the above address or by calling or E-Mailing the following:

TOLL FREE: 1-888-881-8101, Mon. - Fri., 7:30 a.m. - 6:00 p.m. CST

E-mail: farberware-electric@saltonusa.com

Please refer to Model FSCM100 when you call, write or E-Mail.

**FARBERWARE® is a registered trademark of Farberware Inc.®**

**Manufactured and sold pursuant to a license from Farberware Inc.®**