

OWNER'S MANUAL

Model No. GFSB1

GEORGE FOREMAN[®]

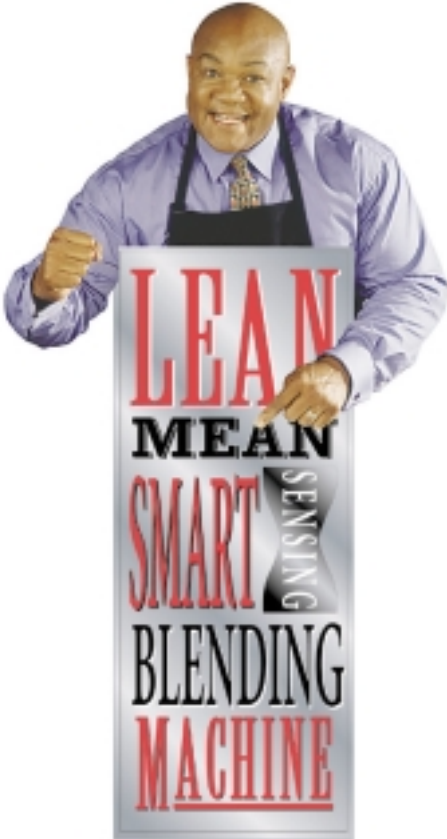

BRAIN STORM[™] TURBO SMART BLENDER



IMPORTANT SAFEGUARDS

When using electrical appliances, basic safety precautions should always be followed including the following:

1. Read all instructions.
2. To protect against risk of electrical shock do not put cord, plugs, or appliance in water or other liquid.
3. Close supervision is necessary when any appliance is used by or near children.
4. Unplug from outlet when not in use, before putting on or taking off parts, and before cleaning.
5. Avoid contacting moving parts.
6. Do not operate any appliance with a damaged cord or plug or after the appliance malfunctions, or is dropped or damaged in any manner. Contact Consumer Service for examination, repair or electrical or mechanical adjustment.
7. The use of attachments, including canning jars, not recommended by the manufacturer may cause a risk of injury to persons.
8. Do not use outdoors.
9. Do not let cord hang over edge of table or counter.
10. Do not let cord contact hot surface, including the stove.
11. Keep hands and utensils away from Blade Assembly and out of container while blending to reduce the risk of severe injury to persons or damage to the Blender. A scraper may be used but must be used only when the Blender is not running.
12. Blades are sharp. Handle carefully.
13. To reduce the risk of injury, never place Blade Assembly on Motor Housing without Blending Container properly attached.
14. Always operate Blender with Lid in place.
15. When blending hot liquids, remove center piece of two-piece Lid.

SAVE THESE INSTRUCTIONS

FOR HOUSEHOLD USE ONLY

Additional Important Safeguards

1. All users of this appliance must read and understand this Owner's Manual before operating or cleaning this appliance.
2. The cord to this appliance should be plugged into a 120V AC electrical outlet only.
3. Do not leave this appliance unattended during use.
4. If this appliance begins to malfunction during use, immediately press the Power On/Off Button to Off and unplug the cord. Do not use or attempt to repair the malfunctioning appliance.
5. If this appliance falls or accidentally becomes immersed in water, unplug it immediately. **Do not reach into the water!** Do not use this appliance after it has fallen into or has become immersed in water.
6. To reduce the risk of injury to persons or property, never use this appliance in an unstable position.
7. Do not use this appliance for other than its intended use.
8. Do not use the Blender Container if cracked or chipped.

Grounded 3-Conductor Plug

This appliance is equipped with a grounded-type 3-wire cord (3-prong plug). This plug will only fit into an electrical outlet made for a 3-prong plug. This is a safety feature. If the plug should fail to fit the outlet, contact an electrician to replace the obsolete outlet. Do not attempt to defeat this safety feature.

Short Cord Instructions

A short power-supply cord is provided to reduce the risk resulting from becoming entangled in or tripping over a longer cord.

Do not use an extension cord.

Electric Power

If the electrical circuit is overloaded with other appliances, your appliance may not operate properly. It should be operated on a separate electrical circuit from other appliances.

Plasticizer Warning

CAUTION: To prevent Plasticizers from migrating from the finish of the counter top or table top or other furniture, place NON-PLASTIC coasters or placemats between the appliance and the finish of the counter top or table top.

Failure to do so may cause the finish to darken, permanent blemishes may occur or stains can appear.

Getting to Know Your Smart Blender

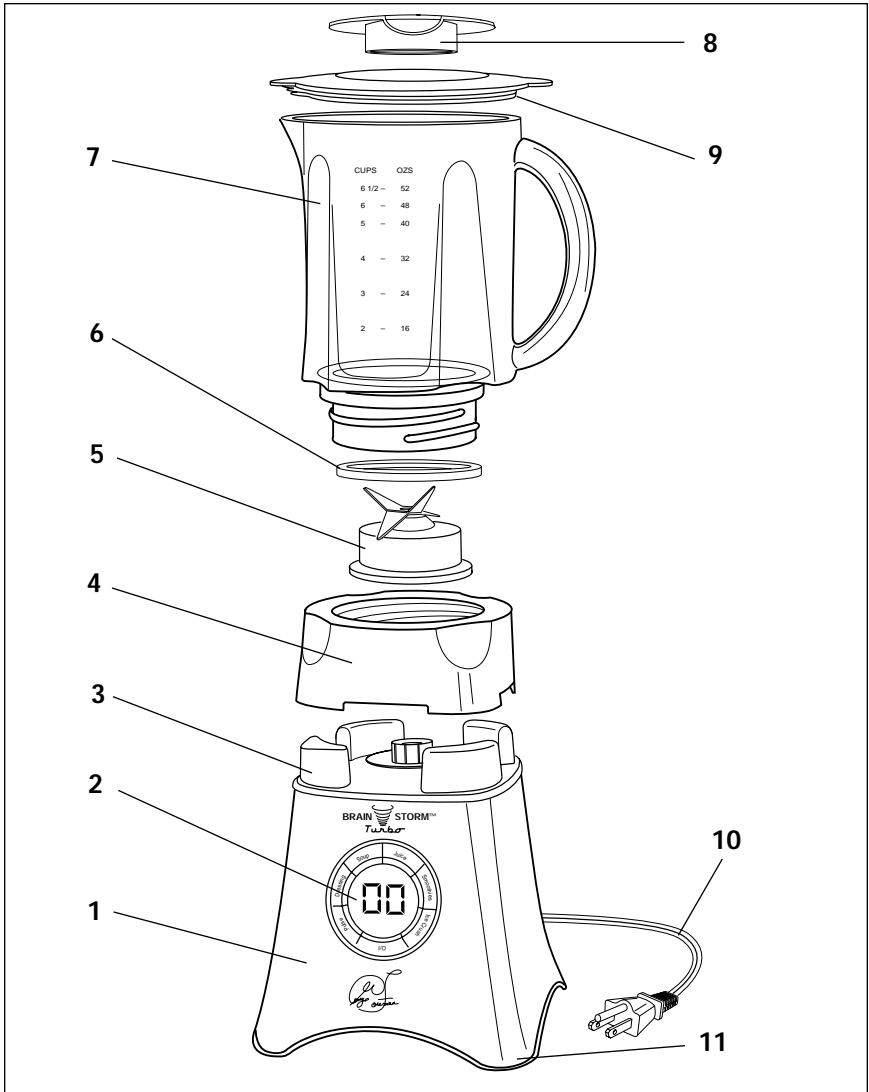

- 1. Motor Housing
- 2. Control Panel
- 3. Rubber Pad (P/N 71245)
- 4. Collar (P/N 71246)
- 5. Blade Assembly (P/N 71247)
- 6. Rubber Seal Ring (P/N 71248)
- 7. Blender Container (P/N 71249)
- 8. Measuring Cap (P/N 71250)
- 9. Lid (P/N 71251)
- 10. Power cord
- 11. Non-Slip Rubber Feet

Control Panel

1. Power On/Off Button
2. Pulse Button
3. Dressing Function
4. Soup Function
5. Juice Function
6. Smoothies Function
7. Ice Crush Function
8. Indicator Light (LED)
9. Display Window

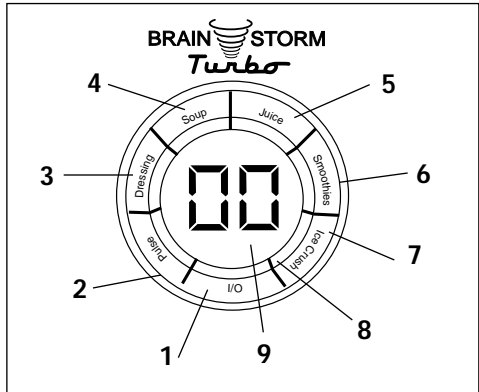

Functions

Pulse - Press and hold for manual control with maximum power, allowing you to prepare bread crumbs, grind chocolate and finely chop nuts. Pulse setting can be used to create the texture or consistency you prefer. You can also use the Pulse setting for cleaning the interior of the Blender Container. See the *User Maintenance Instructions* for details.

Dressing - Get creative and liven up a routine salad or appetizer with a flavorful dressing or dip. See the *Recipe Section* for some suggestions. With preprogrammed time and speed, this function selection will automatically mix the ingredients and stop when proper consistency is achieved.

Soup - Add your favorite fresh vegetables and stock for a healthy and hearty home made soup. With preprogrammed time and speed, this function will automatically mix the ingredients and stop when proper consistency is achieved.

Juice - Add your favorite combination of fresh fruits or vegetables to the Blender Container, turn the blender on and press the Juice Button. This function will automatically mix the ingredients and stop when proper consistency is achieved. You may want to strain some of the juice after blending; however, straining the juice will remove some of the fiber and pith that are healthy additions to your diet.

Smoothies - Refreshing and nutritious smoothies are possible at home with the press of a button. Just add the fruit, milk or yogurt of your choice, turn the blender on and press the Smoothie function to liquefy the ingredients. This function will automatically mix the ingredients and stop when proper consistency is achieved. See the *Recipe Section* for some suggestions.

Ice Crush - This multi-function selection first processes the ice cubes with short bursts of power action until the ice is fully crushed.

Add 1 cup of ice cubes, about 9, to the Blender Container. Turn the Power Button On and press the Ice Crush Button. With preprogrammed time and speed, this function will automatically crush the ice and turn off. If so desired, press the Power On/Off Button to Off to stop the Blender when the ice has been processed to your liking.

Introduction

Congratulations on your purchase of the Brain Storm™ Turbo Blender. This intelligent and versatile appliance determines the appropriate processing speed and time to consistently prepare dressings, soups, juices, smoothies and crushed ice. The Blender automatically stops when blending has reached the ideal consistency. The dual action blade assembly automatically distributes ingredients from top to bottom to aid in processing and eliminate jamming. It's equipped with a generous 52 ounce capacity blender container and an easy to read one-touch Smart function control panel.

Features

Control Panel - The electronic Control Panel allows for effortless operation. Using the built-in Smart functions a wide variety of foods, from salad dressings to crushed ice, can be processed to an ideal consistency with the touch of a button

Two-Piece Blender Lid - Conveniently measure and add additional ingredients through the opening of the two piece lid during processing. When processing hot ingredients, remove the Measuring Cap from the Lid to allow steam to escape.

Before First Use

CAUTION: Use extreme care when handling the Blade Assembly. Do not touch the Blades with your fingers. The Blades are very sharp and can cause injury if touched.

1. Carefully unpack the Blender.
2. Wash the Blender Container, Lid, Measuring Cap and the Blade Assembly in warm soapy water. Rinse and dry thoroughly.
3. Make sure the cord is unplugged and wipe the Motor Housing clean with a moistened cloth. Dry thoroughly.

CAUTION: Never immerse the Motor Housing, plug or cord in water or any other liquid.

Assembly Instructions

CAUTION: Use extreme care when handling the Blade Assembly. Do not touch the Blades with your fingers. The Blades are very sharp and can cause injury if touched.

1. Turn the Blender Container upside down. Place the Rubber Seal Ring over the opening on the bottom of the Blender Container.
2. Carefully insert the Blade Assembly into the opening at the bottom of the Container.
3. Place the Collar over the Blade Assembly and turn the Collar clockwise to engage the threads. To securely tighten, continue turning until the indentations in the Collar align with the indentations in the Blender Container.

NOTE: The Blade Assembly must be firmly attached to the Blender Container before use.

4. Place the Rubber Pad on top of the Motor Housing. Make sure that the center opening of the Rubber Pad is seated beneath the Blade Assembly drive gear.

NOTE: The Rubber Pad must be properly in place before operating the Blender.

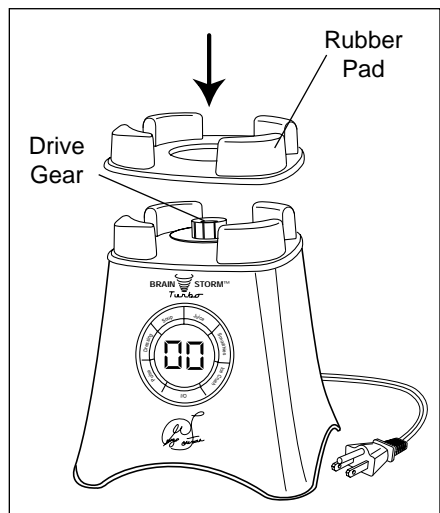
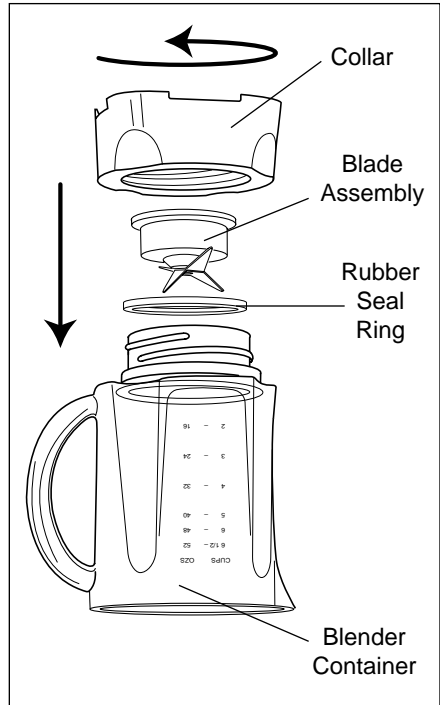

Instructions For Use

CAUTION: *Keep hands and utensils out of the Container while blending to prevent the possibility of severe injury to persons or damage to the unit. A scraper may be used but must only be used when the unit is not running.*

CAUTION: *Use extreme care when handling the Blade Assembly. Do not touch the Blades with your fingers. The Blades are very sharp and can cause injury if touched.*

1. Place the Motor Housing on a clean, dry surface to prevent debris being pulled into the motor during operation.
2. Make sure that the Blade Assembly, Rubber Seal Ring and Collar are properly assembled and securely fastened to the Blender Container. See *Assembly Instructions* for details.
3. Place the Blender Container on the Motor Housing, making sure it is properly seated and not tilting to one side.

CAUTION: *Never place the Blade Assembly on the Motor Housing without the Blender Container being completely assembled and securely tightened.*

4. Add ingredients to the Blender Container. Align the spout seal of the Lid with the spout of the Blender Container and firmly press the Lid down into place.

NOTE: Do not fill the Container with more than 52 ounces of ingredients (6 1/2 cups). **Never operate the Blender when the Container is empty.**

5. Insert the Measuring Cap into the center of the Lid and press down to engage the tabs. The Measuring Cap may be removed as needed to add additional ingredients during processing. However, when processing hot foods or liquids, remove the Measuring Cap to allow steam to escape and to prevent pressure build-up.
6. At the start of the blending process, the powerful motor may cause the liquid to surge against the Lid and cause leakage. To prevent leakage, as well as steadying the unit, place one hand firmly on top of the Lid and select your desired blending function. Never lean over the Blender when it is started or while it is running.

7. Plug the power Cord into a 120V AC electrical outlet. Press the Power On/Off Button to On. The red Indicator Light will illuminate and 00 will appear in the Display Window. Press the desired function button. The orange function Indicator Light will illuminate. The Blender will begin its operation. The Display Window will indicate the preset processing time and begin counting down.

CAUTION: If Container rotates during blending, immediately press the Power On/Off Button to Off, then secure by tightening the Collar and Blade Assembly on Blender Container.

8. Once the countdown is complete and the desired results have been attained the blender will stop automatically. The unit will beep 4 times and the Indicator Lights will go out. Remove the plug from the electrical outlet.
9. Clean unit as instructed in the *User Maintenance Instructions*.

Hot Ingredients

CAUTION: Use extreme caution when blending hot liquids to avoid accidental scalding or burns. Do not use your hand to cover opening!

NOTE: When processing hot foods, always remove the Measuring Cap from the Lid before beginning.

- DO NOT put more than one cup of hot ingredients into the Blender Container before beginning blending.
- After the blending process has begun, you may slowly add up to an additional 1 cup of hot ingredients through the center hole in the Lid.
- Always use a vessel with a pouring spout when adding hot ingredients.

Helpful Hints

- Add ingredients to Blender Container a little at a time to ensure proper blending and prevent overflow. Never fill Blender Container with more than 52 ounces of ingredients (6 1/2 cups); the action of the Blade will cause ingredients to rise in the Container. Make large recipes in several batches.
- Place liquid ingredients into the Blender first, unless recipe instructs otherwise. The liquid will speed processing.
- Always secure the Lid on the Blender Container before operating. Firmly press the spout end of the Lid into position on the Blender Container then press the opposite end of the Lid into place. When removing the Lid, be sure to hold the Blender Container by the Handle before lifting the Lid to avoid tipping the Container.
- Do not remove Blender Container from the Motor Housing while the motor is running.
- Thick mixtures require special attention during processing. Turn Blender off if blending stops or ingredients stick to sides of the Container. Remove the Lid and, with a rubber spatula, push the mixture toward the blades. Replace the Lid and continue processing.
- Extra ingredients may be added while blending by removing the Measuring Cap on top of Lid. Add solids and ice a little at a time through the hole in the Container Lid. Always cut solid foods, such as vegetables and cheese, into small chunks before placing in the Blender Container.
- To reduce wear on the Blade Assembly, place solid food portions in Blender 1/2 cup at a time. Raw fruits and vegetables as well as cooked meats should be cut into 1 inch pieces before processing.
- Remove thick mixtures easily through bottom of the Blender Container after removing the Collar and Blade Assembly.
- Do not store food in Blender.
- To prevent excessive heat expansion, always remove Measuring Cap from Lid when processing hot ingredients. Add hot foods slowly (to a maximum of 2 cups).

User Maintenance Instructions

This Blender requires little maintenance. It contains no user serviceable parts. Do not try to repair it yourself. Any servicing requiring disassembly must be performed by a qualified appliance repair technician.

CAUTION: Never immerse the Motor Housing, plug or cord in water or any other liquid.

1. Always unplug the unit before cleaning.
2. Whenever possible, rinse parts immediately after processing to make cleanup easier.

CAUTION: Use extreme care when handling the Blade Assembly. Do not touch the Blades with your fingers. The Blades are very sharp and can cause injury if touched.

3. Wash the Blender Container, Lid, Measuring Cap and Blade Assembly in warm soapy water. Rinse and dry thoroughly. Never use rough scouring pads or abrasive cleansers on any plastic or metal parts as the surface may be damaged. Only the Blender Container may be washed in the dishwasher.
4. If necessary, wipe exterior surfaces with a moist cloth or sponge and dry thoroughly.
5. Do not fill the Blender Container with boiling water or place any of the parts in boiling water.
6. Do not allow the Blade Assembly to soak in water for long periods of time.
7. Quick clean-ups of the interior of the Blender Container can be made by using the Pulse function. Plug the Blender into an electrical outlet then pour some warm water and a very small amount of detergent into the Blender Container. Place the Lid with Measuring Cap on the Blender Container then press the Pulse button several times. The unit will clean itself without you having to handle the sharp Blades. Unplug the Blender, rinse and dry thoroughly, being careful as the Blades are sharp.
8. Properly reassemble all parts before storing.

STORAGE

CAUTION: Always assemble clean Blender parts correctly before storing on the Motor Housing. Severe injury can result if Blender is accidentally turned ON when not properly assembled.

Unplug and clean unit. Store in original box or in a clean, dry place. Never store Blender while it is hot or plugged in. Never wrap cord tightly around the appliance. Never place any stress on cord, especially where the cord enters the unit, as this could cause the cord to fray and break.

Recipes

Dressings and Dips

Spicy Cottage Cheese Dressing

- 1 cup low-fat cottage cheese
- 1 cup tomato juice
- 1/2 cup vegetable oil
- 1/2 teaspoon hot pepper sauce
- 1 green onion, cut in pieces

Place all of the ingredients in the Blender. Secure the Lid. Press the **Dressing** Button. Chill before serving.

Makes 2 cups.

Santa Fe Dressing

- 1/2 cup soy sauce
- 1/4 cup lemon juice
- 1/4 cup peanut oil
- 1/4 cup olive oil
- 1 jalapeño pepper, stemmed, seeded, and cut in pieces
- 1/2 cucumber, peeled, seeded, and cubed
- 1/2 red onion, cut in pieces
- 1/2 cup packed fresh cilantro leaves, stripped from stems

Place all of the ingredients in the Blender. Secure the Lid. Press the **Dressing** Button. Chill before serving.

Makes 2 cups.

Hummus Dip

15 ounce can cannellini white kidney beans
3 cloves garlic
1/4 cup tahini (sesame seed paste)
3 tablespoons lemon juice
3/4 teaspoon ground cumin
1 teaspoon salt
1/2 teaspoon black pepper
3 tablespoons white kidney bean liquid

Drain the beans and reserve 3 tablespoons of the liquid.

Place the garlic in the Blender. Secure the Lid. Press the **Pulse** Button 10 times.

Place all the remaining ingredients including the 3 tablespoons of bean liquid in the Blender. Secure the Lid. Press the **Dressing** Button. Refrigerate the hummus for several hours to enhance the flavors.

Serve with crackers, pita or tortilla chips.

Makes 1 1/2 cups.

Fresh Salsa

10 Roma tomatoes, cored, seeded, and cut in pieces
1 jalapeño pepper, stemmed, seeded, and cut in pieces
1 large onion, cut in pieces
1/2 cup packed fresh cilantro leaves, stripped from the stems
1 teaspoon cider vinegar
1 teaspoon salt
1/2 teaspoon black pepper

Mix the tomatoes, jalapeño pepper, onion, and cilantro together in a bowl. Place half of the tomato mixture in the Blender. Secure the Lid. Press the **Dressing** Button. Remove from the blender and repeat with the remaining tomato mixture. Mix the two tomato batches together and stir in the vinegar, salt, and black pepper. Cover and refrigerate for 2 hours to enhance flavors.

Makes 3 cups.

Recipes (Cont.)

Soups

Bulgarian Cold Cucumber Soup

- 1 clove garlic
- 1 cucumber, peeled, seeded, and cubed
- 1 1/2 cups plain low-fat yogurt
- 1 teaspoon salt
- 1/4 teaspoon white pepper
- 1/2 cup walnuts
- 2 tablespoons olive oil
- 2 tablespoons chopped fresh dill
- 1/3 cup ice cubes

Place the garlic in the blender. Secure the lid. Press the **Pulse** Button 10 times. Add the remaining ingredients. Secure the lid. Press the **Soup** Button. Serve immediately.

Makes 3 cups.

Low-Fat Creamy Vegetable Soup

- 1/4 cup low-fat margarine
- 1 cup chopped cauliflower
- 1 cup chopped broccoli
- 1/4 cup chopped carrots
- 1/4 cup chopped onion
- 12 ounce can fat-free evaporated skim milk
- 1 cup low-fat chicken broth
- Salt and pepper to taste

Melt the butter in a pan and sauté vegetables until tender. Cool.

Place the evaporated milk, broth, and the sautéed vegetables in the Blender. Secure the Lid. Press the **Soup** Button. Pour mixture back into the pan, stir in the evaporated skim milk and heat to simmer, stirring occasionally. Serve hot.

Makes 4 cups.

Soups *Continued*

Garden Tomato Soup

1/2 cup low-fat plain yogurt
1 tablespoon lime juice
1 1/2 teaspoons sugar
1 green onion, cut in pieces
3 medium tomatoes, cored, seeded and cut in pieces
Salt and pepper to taste

Place all of the ingredients in the Blender. Secure the Lid. Press the **Soup** Button. Heat to a boil, stirring occasionally.

Makes 2 cups.

Chilled Gazpacho

1 clove garlic
1 1/2 cups tomato juice
1/2 rib celery, cut in pieces
1/2 cucumber, peeled, seeded, and cubed
1/4 yellow bell pepper, cored, seeded, and cut in pieces
1/4 red bell pepper, cored, seeded, and cut in pieces
1/2 to 1 habanero chile pepper, cored, seeded, and cut in pieces
3 green onion, cut in pieces
2 medium tomatoes, cored, seeded, and cut in pieces
1 1/2 tablespoons lemon juice
1/4 teaspoon salt

Place the garlic in the Blender. Secure the Lid. Press the **Pulse** Button 10 times. Add the remaining ingredients. Secure the lid. Press the **Soup** Button. Chill 3 hours before serving.

Makes 4 cups.

Recipes (Cont.)

Juices

Pineapple Orange Juice

1 cup chopped pineapple
3 oranges, peeled, seeded, and sectioned
1 lemon, peeled, seeded, and cut in pieces

Place all of the ingredients in the Blender. Secure the Lid. Press the **Juice** Button. Serve.

Makes 3 cups.

Apple Lemon Juice

Small piece of fresh ginger, peeled
4 apples, cored and cubed
1 lemon, peeled, seeded, and cut in pieces

Place the ginger in the Blender. Secure the Lid. Press the **Pulse** Button 10 times.

Place the remaining ingredients in the Blender. Secure the Lid. Press the **Juice** Button. Serve.

Makes 3 1/2 cups.

Cranberry Refresher Juice

2 cups cold cranberry juice
2 cups ice
1/4 cup powdered sugar
1/2 teaspoon vanilla

Place all of the ingredients in the Blender. Secure the Lid. Press the **Juice** Button. Serve.

Makes 4 cups.

Spicy Tomato Juice

1 1/2 cups tomato juice
1/2 cucumber, peeled, seeded, and cubed
1 rib celery, cut in pieces
1 slice lime, peeled
2 to 3 drops hot pepper sauce
Salt and pepper to taste

Place all of the ingredients in the Blender. Secure the Lid. Press the **Juice** Button. Serve.

Makes 1 1/2 cups.

Smoothies

Strawberry Banana and Pineapple Smoothie

1 cup low-fat plain yogurt
2 bananas, peeled and cubed
1 cup fresh chopped pineapple
2 cups fresh strawberries, stemmed and halved
1 cup ice cubes

Place all of the ingredients in the Blender. Secure the Lid. Press the **Smoothie** Button. Serve.

Makes 5 cups.

Mocha Frappe

1 1/2 cups cold skim milk
2 teaspoons instant coffee drink mix
1/4 teaspoon ground cinnamon
2 cups fat-free chocolate frozen yogurt

Place all of the ingredients in the blender. Secure the lid. Press the **Smoothie** Button. Serve.

Makes 2 cups.

Recipes (Cont.)

Smoothies *Continued*

All Fruit Smoothie

- 1/2 cup orange juice
- 1 cup chopped pineapple
- 1 cup mandarin orange segments, drained
- 1 cup chopped cantaloupe
- 1 cup strawberries, stemmed and halved
- 1 cup raspberries
- 1 banana, peeled and cubed
- 1 cup ice cubes

Place all of the ingredients in the Blender. Secure the Lid. Press the **Smoothie** Button. Serve.

Makes 5 cups.

Orange Frosty

- 6 ounce can frozen orange juice concentrate
- 1 cup cold water
- 1 cup cold skim milk
- 1/2 cup sugar
- 1 teaspoon vanilla
- 1 cup ice cubes

Place all of the ingredients in the Blender. Secure the Lid. Press the **Smoothie** Button. Serve.

Makes 4 cups.

LIMITED ONE-YEAR WARRANTY

Warranty Coverage: This product is warranted to be free from defects in materials or workmanship for a period of one (1) year from the original purchase date. This product warranty is extended only to the original consumer purchaser of the product and is not transferable. For a period of one (1) year from the date of original purchase of the product, our Repair Center will, at its option, either (1) repair the product or (2) replace the product with a reconditioned comparable model. These remedies are the purchaser's exclusive remedies under this warranty.

Warranty Service: To obtain warranty service, you must call our warranty service number at 1-800-233-9054 for return instructions on how to deliver the product, in either the original packaging or packaging affording an equal degree of protection to the Repair Center specified below. You must enclose a copy of your sales receipt or other proof of purchase to demonstrate eligibility for warranty coverage.

To return the appliance, ship to: To contact us, please write to, call, or email:

ATTN: Repair Center
708 South Missouri Street
Macon, MO 63552 USA

Consumer Relations Department
PO Box 7366
Columbia MO 65205-7366 USA
1-800-233-9054
E-mail: consumer_relations@toastmaster.com

What Is Not Covered: This warranty does not cover damage resulting from misuse, accident, commercial use, improper service or any other damage caused by anything other than defects in material or workmanship during ordinary consumer use. This warranty is invalid if the serial number has been altered or removed from the product. This warranty is valid only in the United States and Canada.

LIMITATION ON DAMAGES: THERE SHALL BE NO LIABILITY FOR ANY INCIDENTAL OR CONSEQUENTIAL DAMAGES FOR BREACH OF ANY EXPRESS OR IMPLIED WARRANTY OR CONDITION ON THIS PRODUCT.

DURATION OF IMPLIED WARRANTIES: EXCEPT TO THE EXTENT PROHIBITED BY APPLICABLE LAW, ALL IMPLIED WARRANTIES AND CONDITIONS, INCLUDING, WITHOUT LIMITATION, IMPLIED WARRANTIES AND CONDITIONS OF MERCHANTABILITY AND FITNESS FOR A PARTICULAR PURPOSE OR USE ON THIS PRODUCT ARE LIMITED IN DURATION TO THE DURATION OF THIS WARRANTY.

Some jurisdictions do not allow the exclusion or limitation of incidental or consequential damages, or allow limitations on how long an implied warranty lasts, so the above limitations or exclusions may not apply to you. This warranty gives you specific legal rights and you may have other rights under the laws of your jurisdiction.

For more information on our products, visit our website:
www.maxim-toastmaster.com.