

OWNER'S MANUAL

**Model No. GGR200RDDS
GGR200BN**

GEORGE FOREMAN®



INDOOR / OUTDOOR GRILL

IMPORTANT SAFEGUARDS

When using electrical appliance, basic safety precautions should always be followed, including the following:

1. Read all instructions.
2. Do not touch hot surfaces. Use handles or knobs.
3. To protect against electrical shock do not immerse cord, plugs, or appliance in water or other liquid.
4. Close supervision is necessary when any appliance is used by or near children.
5. Unplug from outlet when not in use and before cleaning. Allow to cool before putting on or taking off parts, and before cleaning the appliance.
6. Do not operate any appliance with a damaged cord or plug or after the appliance malfunctions or has been damaged in any manner. Return appliance to the nearest authorized service facility for examination, repair or adjustment.
7. The use of accessory attachments not recommended by the appliance manufacturer may cause injuries.
8. Do not let cord hang over edge of table or counter, or touch hot surfaces.
9. Do not place on or near a hot gas or electric burner, or in a heated oven.
10. Do not place Grill Base or Pedestal on top of hot surface.
11. Extreme caution must be used when moving an appliance containing hot oil or other hot liquids. Allow grease or oil to cool before disposal.
12. Always attach Temperature Control Probe to Grill before plugging cord into wall outlet. To disconnect, turn Temperature Control Probe to "Off", then remove plug from wall outlet.
13. Do not use appliance for other than intended use.
14. Fuel, such as charcoal briquettes, is not to be used with appliance.
15. Use only on properly grounded outlet.
16. CAUTION – To ensure continued protection against risk of electric shock, connect to properly grounded outlets only.
17. CAUTION – To reduce the risk of electric shock, keep extension cord connection dry and off the ground

SAVE THESE INSTRUCTIONS
Household Use Only

ADDITIONAL IMPORTANT SAFEGUARDS

WARNING: This appliance produces heat and escaping steam during use. Proper precautions must be taken to prevent risk of burns, fire or other injury to persons or damage to property.

When using electrical appliances, basic safety precautions should always be followed to reduce the risk of fire, electric shock and injury to persons, including the following :

Never use your INDOOR/OUTDOOR BARBEQUE GRILL without the Grill Base.

1. All users of this appliance must read and understand this Owner's Manual before operating or cleaning this appliance.

2. Cord to this appliance should be plugged into a 120V AC electrical outlet only.

3. If this appliance begins to malfunction during use, immediately unplug the cord. Do not use or attempt to repair the malfunctioning appliance.

4. If this appliance falls or accidentally becomes immersed in water, unplug it from the outlet immediately. Do not reach into the water!

5. When using this appliance, provide adequate air space above and on the sides of the unit for air circulation. Do not operate this appliance if it is near or touching curtains, wall coverings, clothing or other flammable materials.

6. Do not place any of the following materials in or on the Grill Plate : paper, plastic and the like.

7. Do not clean with metal scouring pads or harsh abrasives. TO do so will damage the non-stick coating.

8. This appliance is not for use by children.

9. Do not use while standing in a damp area.

10. Do not attempt to dislodge food or to clean the grill when it is hot.

11. Do not leave this appliance unattended while in use.

12. Do not operate the Grill without the Drip Tray in place.

Grounded 3-Conductor Plug

This appliance is equipped with a **grounded-type 3-wire cord** (3-prong plug) the plug will only fit into an electrical outlet made for a 3-prong plug. This is a safety feature. If the plug should fail to fit the outlet, contact an electrician to replace the obsolete outlet. Do not attempt to defeat this safety feature.

Short Cord Instructions

A short power supply cord is to be provided to reduce the risk resulting from becoming entangled in or tripping over a longer cord. An extension cord is available and may be used if care is exercised in their use. If an extension cord is used, the marked electrical rating of the extension cord should be at least as great as the electrical rating of the appliance. If the appliance is of the grounded type, the extension cord should be a grounded 3-wire cord. The extension cord should be arranged so that it will not drape over the countertop or tabletop where it can be pulled on by children or tripped over unintentionally. Outdoor extension cords should be used with outdoor use products and are surface marked with suffix letters "W-A" and with a tag stating "Suitable for Use with Outdoor Appliance." The connection to an extension cord should be kept dry and off the ground. Store products indoors when not in use- out of the reach of children. Do not clean this product with a water spray or the like.

Electric Power

Do not overload the electrical circuit with other appliances. Operate this appliance on a separate electrical circuit.

Getting To Know Your GGR200RDDS & GGR200BN Grill

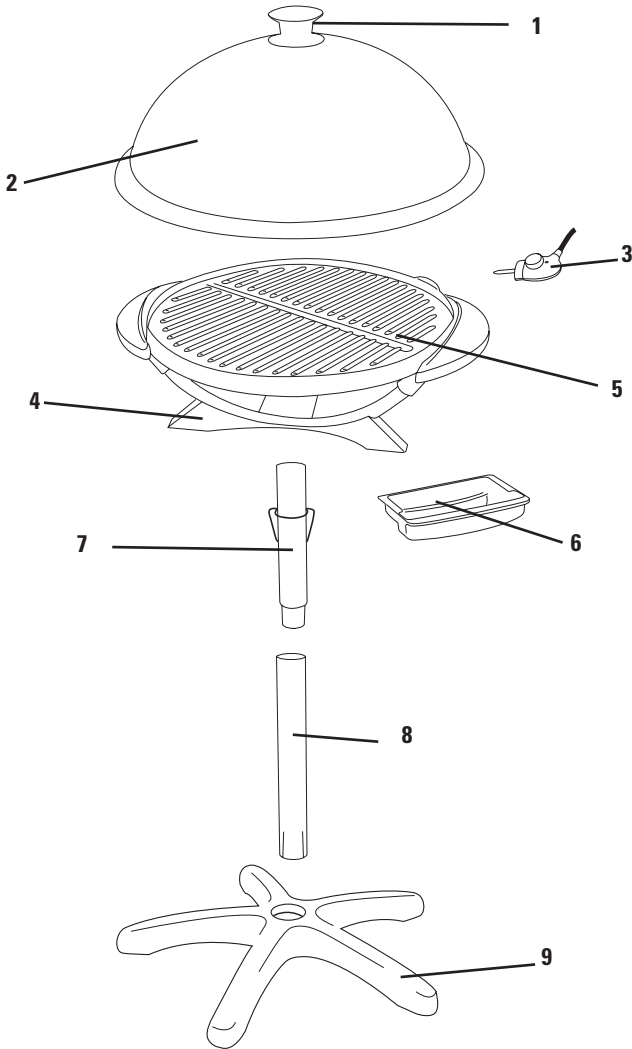

Fig. 1

- | | |
|---|-------------------------------------|
| 1. Lid Knob (p/n 22864) | 4. Grill Base (p/n 22861) |
| 2. Lid (p/n 22859)
*lid color is only available
in silver | 5. Grill Plate |
| 3. Temperature Control Probe
(p/n 22860) | 6. Drip Tray (p/n 22862) |
| | 7. Upper Pedestal Tube (p/n 22870) |
| | 8. Lower Pedestal Tube (p/n 22871) |
| | 9. Pedestal Stand (p/n 22863) |

Assembly Instructions

Unpack your George Foreman Grill and check that all the parts are present. (See fig. 1)

1. Before first use wash the grill plate, drip tray and lid in warm soapy water. Wipe it off with a damp cloth and dry thoroughly.
DO NOT IMMERSE THE TEMPERATURE CONTROL PROBE IN WATER.
2. Place the Pedestal Stand on a flat, level surface.
3. Insert the slotted end of the Lower Pedestal Tube into the hole in the center of the Pedestal Stand and push down firmly.
4. Insert the tapered end of the Upper Pedestal Tube into the top of the Lower Pedestal Tube and screw the Tubes together.
5. Place the Grill Base on top of the Pedestal Tube assembly through the hole in the center of the Grill Base. Rotate slightly so that the tabs on the Pedestal Tube assembly align with the slots in the Grill Base and the Grill Base is level. Lift the Locking Latch up so it mates with the Locking Ring on the Bottom of the Grill Base and firmly lock into place.
6. Slide the Drip Tray into position using the guiding rails into the Grill Base.
7. Attach the Lid Knob to the Lid from inside the Lid.
8. Place the Lid over the Grill. Your Barbeque Grill is now ready for use.

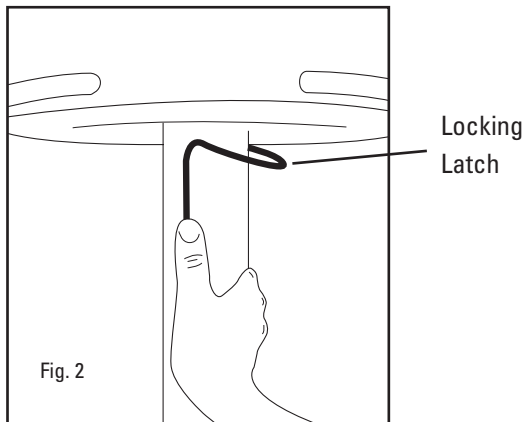

How to Use George Foreman's Indoor/Outdoor Electric Barbeque Grill

1. Turn temperature control probe to OFF position and attach securely into the probe receptacle.
2. Plug into 120V-60Hz outlet. Align desired temperature setting with the indicator light. Place Lid securely on Grill. Allow Barbeque Grill to pre heat to desired temperature for approximately 10 minutes. See cooking charts for more details.
3. Carefully lift the Lid and place food onto Grill Plate, and cover, for most food. Adjust temperature as needed. The light on the Temperature Control Probe will cycle on and off as the thermostat maintains the proper temperature. This is normal operation.
NOTE: Condensation may collect on the inside of the lid when cooking. Use caution when opening lid.
4. When finished cooking, turn temperature control probe to OFF position. The indicator light will go off. Unplug and allow to cool before dis-assembling and cleaning. See User Maintenance Instructions.
NOTE: The temperature control probe may be turned to setting 1 to keep foods warm for short periods of time.

Hints for Grilling

- Use tender cuts of meat for grilling.
- Marinate tougher cuts of meat to tenderize them before grilling.
- To avoid drying out meat and fish, turn only once and do not pierce.
- To turn meat and fish, use a large flat plastic or wooden spatula to support the food.
- Place meat or chicken to be roasted in a shallow baking pan. Cover pan with a lid or foil. Using oven mitts, carefully place pan on preheated Grill, taking care not to scratch the non-stick surface. Place Lid on the Barbeque Grill.
- Use only plastic or wooden utensils on non-stick surface.

CAUTION: Because some countertop finishes are more affected by heat than others, make sure countertop surface can withstand temperatures of 150°F to prevent discoloration or other damage to the countertop surface.

CAUTION: Grill surfaces are hot during use. Allow Grill Plate, Grease Tray, Lid and Base to cool completely before handling and cleaning. DO NOT clean this product with a water spray or the like.

Using Indoors

To use your INDOOR/OUTDOOR BARBEQUE GRILL indoors, simply unsnap the Locking Latch from the Grill Base and lift the Grill Base unit off the Pedestal Tube and place on a heat resistant surface.

Plasticizer Warning

CAUTION: To prevent Plasticizers from migrating from the finish of the countertop or tabletop or other furniture, place **NON-PLASTIC** coasters or placemats between the appliance and the finish of the countertop or tabletop.

Failure to do so may cause the finish to darken, permanent blemishes may occur or stains can appear.

User Maintenance Instructions

CAUTION: Grill surfaces are hot during use. Allow Grill Plate, Grease Tray, Lid and Base to cool completely before handling and cleaning. DO NOT clean this product with a water spray or the like.

CAUTION: Do not immerse the temperature control probe in water or any other liquid.

1. Unplug and allow to cool before disassembling and cleaning. Thoroughly clean all parts after each use.
2. Remove Temperature Control Probe (DO NOT IMMERSE). Wipe with a damp cloth and dry thoroughly.
3. Remove the Grill Base from the Pedestal Tube and empty the Drip Tray .
4. Wash the Grill Plate, Drip Tray, and Lid with hot soapy water and a plastic scouring pad. Rinse and dry thoroughly.
5. After washing the Grill Plate wipe the uncoated side with a dry towel to prevent discoloration. Washing may cause oxidation on the uncoated side of the Grill Plate. This is not harmful and may be wipe off with a damp towel.
6. DO NOT WASH THE GRILL PLATE IN THE DISHWASHER.

CAUTION: Temperature Control Probe receptacle must always be completely dry before use.

Suggested Cooking Chart

The following times are meant to be used as guidelines only. Times will vary due to the cut or thickness of the meat being cooked. To be sure that the food is truly done, use a cooking thermometer. If the meat does need more time to cook, simply place the meat back on the grill for 5 minutes increments and check periodically so you don't over cook.

Grill Chart

1. Preheat INDOOR/OUTDOOR BARBEQUE GRILL
2. Grill food according to the recommended time or until desired doneness. Turn halfway through cooking time, or more often if necessary.
3. Boneless cuts of meat will grill more evenly and not scratch the non-stick surface
4. Leave the lid on during cooking to decrease cooking time and keep food moist and juicy.
5. Let thick cuts of meat rest 5 minutes before serving.

Food	Temperature	Time
Chicken Breast halves	4	15-25 minutes
Fish steak 1 inch thick	4	15-25 minutes
Hamburgers (4 oz each)	4	5-10 minutes
Pork chops, 1 inch thick	4	15-30 minutes
Sausage, fresh (do not preheat)	3	10-15 minutes
Steak, 1 inch thick	5	5-15 minutes
Shrimp, 26 to 30 count	4	4-5 minutes

Roasting / Baking Chart

Place meat or poultry in a baking container, cover baking container with aluminum foil or glass lid. Using oven mitts, carefully place baking container on Grill, cover Grill with Lid to keep in moisture.

Food	Amount	Temperature	Time
Beef pot roast	2-3 lbs.	4	2-3 hours
Whole chicken fryer	3-4 lbs	5	1-1.5 hours
Fresh ham	5-7 lbs.	5	1.5-2.5 hours
Pork Roast	2-4 lbs.	4	1.25-2.25 hours
Baking Potato wrapped in foil	1-6	4	1-1.5 hours

NOTE: The United States Department of Agriculture recommends that meat and poultry be cooked to the following internal temperatures to be sure any harmful bacteria has been killed. Ground turkey and chicken should be cooked to an internal temperature of 165°F and ground beef, veal lamb and pork be cooked to an internal temperature of 160°F. Chicken and turkey should be cooked to an internal temperature of 170°F for white meat and 180°F for dark meat. Goose and duck should be cooked to an internal temperature of 180°F. Fresh beef, veal and lamb, ect. should be cooked to an internal temperature of 145°F. Fresh pork should be cooked to an internal temperature of at least 160°F. When re-heating meat and poultry products, they should also be cooked to an internal temperature of 165°F.

LIMITED ONE-YEAR WARRANTY

Warranty Coverage: This product is warranted to be free from defects in materials or workmanship for a period of one (1) year from the original purchase date. This product warranty is extended only to the original consumer purchaser of the product and is not transferable. For a period of one (1) year from the date of original purchase of the product, our Repair Center will, at its option, either (1) repair the product or (2) replace the product with a reconditioned comparable model. These remedies are the purchaser's exclusive remedies under this warranty.

Warranty Service: To obtain warranty service, you must call our warranty service number at 1-800-233-9054 for return instructions on how to deliver the product, in either the original packaging or packaging affording an equal degree of protection to the Repair Center specified below. You must enclose a copy of your sales receipt or other proof of purchase to demonstrate eligibility for warranty coverage.

To return the appliance, ship to: **To contact us**, please write to, call, or email:

ATTN: Repair Center
708 South Missouri Street
Macon, MO 63552 USA

Consumer Relations Department
PO Box 7366
Columbia MO 65205-7366 USA
1-800-233-9054
E-mail: consumer_relations@toastmaster.com

What Is Not Covered: This warranty does not cover damage resulting from misuse, accident, commercial use, improper service or any other damage caused by anything other than defects in material or workmanship during ordinary consumer use. This warranty is invalid if the serial number has been altered or removed from the product. This warranty is valid only in the United States and Canada.

LIMITATION ON DAMAGES: THERE SHALL BE NO LIABILITY FOR ANY INCIDENTAL OR CONSEQUENTIAL DAMAGES FOR BREACH OF ANY EXPRESS OR IMPLIED WARRANTY OR CONDITION ON THIS PRODUCT.

DURATION OF IMPLIED WARRANTIES: EXCEPT TO THE EXTENT PROHIBITED BY APPLICABLE LAW, ALL IMPLIED WARRANTIES AND CONDITIONS, INCLUDING, WITHOUT LIMITATION, IMPLIED WARRANTIES AND CONDITIONS OF MERCHANTABILITY AND FITNESS FOR A PARTICULAR PURPOSE OR USE ON THIS PRODUCT ARE LIMITED IN DURATION TO THE DURATION OF THIS WARRANTY.

Some jurisdictions do not allow the exclusion or limitation of incidental or consequential damages, or allow limitations on how long an implied warranty lasts, so the above limitations or exclusions may not apply to you. This warranty gives you specific legal rights and you may have other rights under the laws of your jurisdiction.

For more information on our products, visit our website: www.igrillwithgeorge.com

"© 2007 All Rights Reserved"

Printed in China
Rev. 12/07