

OWNER'S MANUAL

Model No. GGR57

# GEORGE FOREMAN™



A handwritten signature in black ink that reads 'George Foreman'.



# IMPORTANT SAFEGUARDS

## READ AND SAVE THESE INSTRUCTIONS

**WARNING:** A risk of fire and electrical shock exists in all electrical appliances and may cause personal injury or death. Please follow all safety instructions.

When using electrical appliances, basic safety precautions should always be followed to reduce the risk of fire, electric shock and injury to persons, including the following:

1. Read all instructions before using the appliance.
2. Do not touch hot surfaces. Use handles or knobs. Use of protective oven mitts or gloves is recommended.
3. To protect against electrical shock, do not immerse cord, plug, Temperature Control Probe, or cooking unit in water or other liquid. See Instructions for cleaning.
4. Close supervision is necessary when any appliance is used near children. This appliance is not for use by children.
5. Unplug from outlet when not in use and before cleaning. Allow to cool before putting on or taking off parts, and before cleaning the appliance.
6. Always attach probe to grill before plugging cord into wall outlet. To disconnect, turn temperature control probe to OFF, then remove plug from wall outlet.
7. Do not operate any appliance with a damaged cord or plug or after the appliance malfunctions, or has been dropped or damaged in any manner. Contact consumer service for examination, repair, or adjustment.
8. Do not let cord hang over edge of table or counter, or touch hot surfaces.
9. The use of accessory attachments not recommended by the appliance manufacturer may cause injuries.
10. Do not use while standing in a damp area.
11. Do not place on or near a hot gas or electric burner, or in a heated oven.
12. Do not use appliance for other than intended use.
13. Extreme caution must be used when moving an appliance containing hot oil or other hot liquids. Allow liquid to cool before removing and emptying Drip Cup. Do not remove Grill from Base until Grill is cool.
14. Do not attempt to dislodge food or clean the grill when it is plugged in or when it is hot.
15. Fuel, such as charcoal briquettes, is not to be used with this appliance.
16. Use only on properly grounded outlet.
17. Do not leave this appliance unattended while in use.

## SAVE THESE INSTRUCTIONS

**This Appliance Is For Household Use Only.**

# Additional Important Safeguards

1. **CAUTION: This appliance generates heat and escaping steam during use. Proper precautions must be taken to prevent the risk of burns, fires or other damage to persons or property.**
2. All users of this appliance must read and understand this Owner's Manual before operating or cleaning this appliance.
3. The cord to this appliance should be plugged into a 120V AC ground-ed-type electrical outlet only.
4. When using this appliance, provide adequate air space above and on all sides for air circulation. Do not allow this appliance to touch clothing, dish towels or other flammable materials during use.
5. If this appliance begins to malfunction during use, immediately unplug cord from outlet. Do not use or attempt to repair the malfunctioning appliance.

## Special Considerations for Outdoor Use:

6. Do not use Grill if you or the grill are wet or damp, or when you are standing in a wet or damp area. If it starts to rain while operating the Grill, immediately turn the Temperature Control Probe to OFF. Then unplug the Grill from the electrical outlet and move the Grill indoors until the rain has stopped. Do not attempt to use Grill again until the Grill and Power Cord are wiped completely dry.
7. Do not use or place Grill in an area where it can become wet (near pool or hoses, within sprinkler range, etc.)
8. Do not operate Grill in a high-traffic area.
9. After outdoor use, unplug from electrical outlet and allow Grill to cool completely.
10. We recommend storing Grill indoors or, if unable to store indoors, always cover Grill with protective cover. Always keep out of the reach of children.
11. We do not recommend the use of an extension cord. However, if it is necessary to use an extension cord while operating the Grill outdoors, use only one grounding-type, three-wire extension cord (and it must be specifically for outdoor use and marked with suffix letters "W-A" and with a tag stating "Suitable for Use with Outdoor Appliances"). Be sure the plug from the Grill is fully inserted into the extension cord and that the connection is kept dry and off the ground.
12. Do not clean the Grill with a water spray or the like.

## 3-Prong Grounded Type Plug

This appliance is equipped with a grounded-type 3-wire cord (3-prong plug). This plug will only fit into an electrical outlet made for a 3-prong plug. This is a safety feature. If the plug should fail to fit the outlet, contact an electrician to replace the obsolete outlet. Do not attempt to modify the plug in any way.

## Extension Cord Use

We do not recommend the use of an extension cord; however, if an extension cord is required, special care and caution are necessary. The cord must be a 14 Gauge, Three (3) Conductor type marked with an electrical rating of 120V, 15A, 1875W, and arranged so that it will not drape over the countertop or table top where it can be pulled on by children or tripped over accidentally.

## Electrical Power

If the electrical circuit is overloaded, the circuit breaker will trip and your appliance will not operate. It should be operated on a 20amp electrical circuit separate from other appliances.

## Temperature Control Probe

Use only the Temperature Control Probe (P/N 21006B) supplied with this product. Using any other type of Temperature Control Probe may cause fire, electric shock, or injury.

**CAUTION: The Temperature Control Probe is designed to yield precise results. Use care not to drop, hit or impact it against hard surfaces. Never pull on the cord of the Temperature Control Probe. Always grip the body of the Temperature Control Probe when handling.**

# Getting To Know Your GGR57 Electric Grill

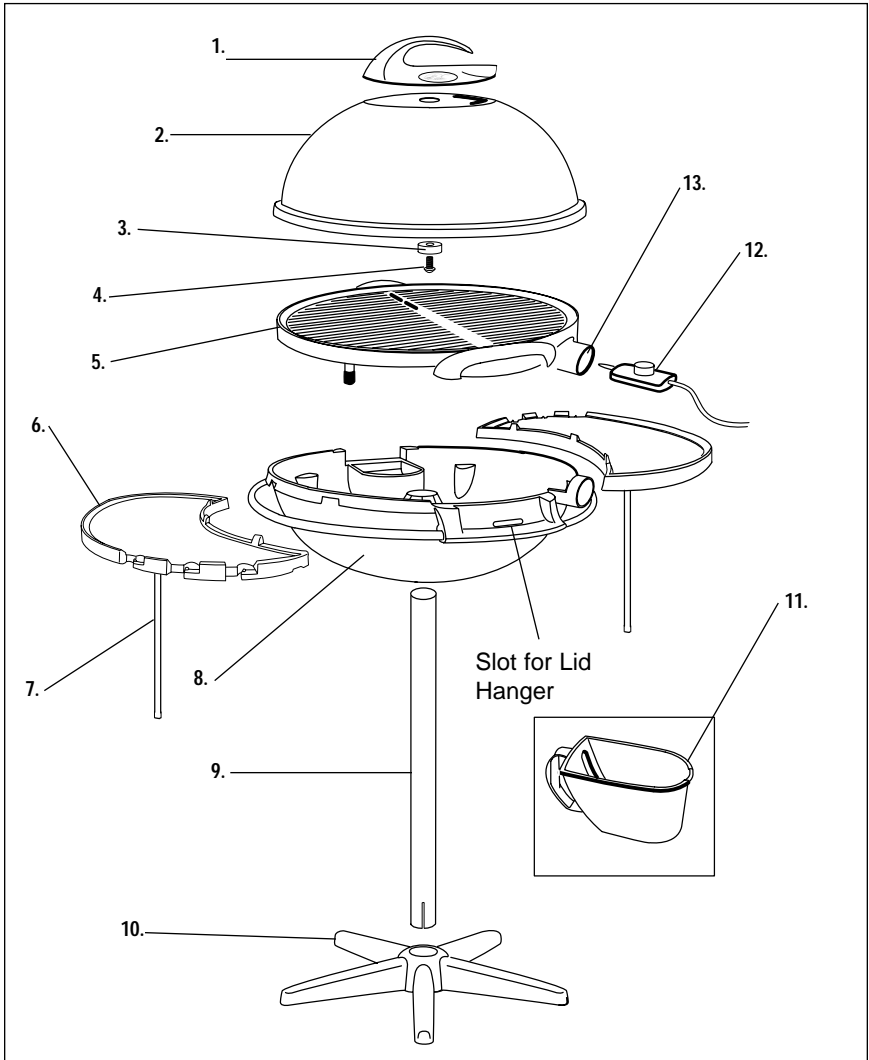

- 1. Lid Handle/Vent (P/N 21303)
- 2. Lid Assembly (P/N 21304)
- 3. Washer } (P/N 21305)
- 4. Screw } (P/N 21305)
- 5. Grill Plate (P/N 21306)
- 6. Side Tray (2) (P/N 21307)
- 7. Side Tray Support Arm (2)

- 8. Grill Base (P/N 21308)
- 9. Pedestal Tube (P/N 21309)
- 10. Pedestal Base (P/N 21310)
- 11. Drip Cup (P/N 21311)
- 12. Temperature Control Probe  
(P/N 21006B)
- 13. Probe Receptacle

# Assembly Instructions

1. Before using the Grill for the first time, wipe the Grill Plate with a damp cloth to remove any dust. Wash the Grill Base, Lid, Side Trays and Drip Cup in warm, soapy water. Rinse and dry thoroughly. **DO NOT IMMERSE TEMPERATURE CONTROL PROBE IN WATER.** Wipe with a damp cloth and dry thoroughly.
2. Place the Pedestal Base on a flat, level surface.
3. Insert the slotted end of the Pedestal Tube into the hole in the center of the Pedestal Base and push down firmly.
4. Place the Grill Base over the Pedestal Tube, align the hole in the Grill base with the Pedestal Tube and press firmly into position.
5. Fully slide the Drip Cup into the Grill Base.
6. Place the Grill Plate upon the Grill Base with the Probe Receptacle fitting through the probe cutout in the top side of the Grill Base.
7. Attach both Side Trays to the Grill by inserting the three raised tabs into the matching notches on the Grill Base, then engage the tabs by sliding the Tray to the left. Raise and fit the foot of each Side Tray Support Arm into the small notch on the lower side of the Grill Base.
8. The Handle/Vent and mounting hardware, (Phillips head Screw and Washer) are packaged separately in a plastic bag. Remove all parts then properly position the Handle/Vent on the top of the Lid. Make sure the Handle/Vent stop pin enters the Vent slot in the Lid. From the inside of the Lid, place the Washer over the stem of the Handle/Vent and securely fasten with the Phillips head Screw.
9. Place the Lid over the Grill. Your Barbecue Grill is now ready to use.

**NOTE:** The Lid has a Hanging Bracket fastened to the inside. When the Lid is to be removed simply slide the Bracket through the rectangular slot in the Grill Base Handle next to the Temperature Control Probe Receptacle.

**CAUTION: Risk of Fire - Never use the Grill without Base.**

# How To Use the George Foreman Electric Grill

**IMPORTANT:** Before operating this Grill outdoors, see "Special Considerations for Outdoor Use" in the "IMPORTANT SAFEGUARDS" and "Additional Important Safeguards" sections of this manual.

1. Turn the Temperature Control Probe to the OFF position. Attach securely into the Probe Receptacle. Make sure the Probe is pushed in as far as possible to assure proper connection.
2. **To preheat:** Use the Handle to close the Lid and plug the cord into a 120V AC grounded outlet. Turn the dial on the Temperature Control Probe to the desired temperature setting. The light on the Temperature Control Probe will illuminate and the Grilling Plate will begin heating. **Allow the unit to preheat for at least 15 minutes before use.**
3. Carefully remove the Lid and place food onto the Grill. Cover for most foods. Cook until done, turning at least once halfway through cooking time for most foods. Adjust temperature as needed.
4. You can control the moisture of foods to some extent by opening or closing the Lid Vent. Turning the Lid Handle/Vent counter-clockwise will open the vent for drier cooking. Turning the Lid Handle/Vent clockwise will reduce the vent opening and retain moisture within the food.

**CAUTION: Condensation may collect on the inside of the Lid when cooking. Use caution when removing lid.**

5. The light on the Temperature Control Probe will cycle on and off as the thermostat maintains the proper temperature. This is normal operation.

**NOTE:** The Temperature Control Probe may be turned to setting 1 to keep foods warm for a short period of time.

6. When the food is cooked, remove with spatula or a plastic or wooden utensil. Be sure to always use either plastic or wooden utensils so as not to scratch the non-stick surface. Never use metal tongs, forks or knives as these can damage the coating on the cooking plates.

**CAUTION: Do not leave any utensils on the Grill Plate surface while it is plugged in or hot.**

7. When finished cooking, turn the Temperature Control Probe to the OFF position. The indicator light will go off. Unplug and allow to cool before disassembling and cleaning.
8. When cool, the Drip Cup may be removed and emptied. **Be sure the liquid has cooled before removing Drip Cup.**

# Grilling Hints and Tips

- Use tender cuts of meat for grilling.
- Marinate tougher cuts of meat to tenderize them before grilling.
- To avoid drying out meat and fish, turn only once and do not pierce.
- To turn meat and fish, use a large flat plastic or wooden spatula to support the food.
- Place meat or chicken to be roasted in a shallow baking pan. Using oven mitts carefully place pan on preheated Grill, taking care not to scratch the non-stick surface. Place Lid on the Barbecue Grill.  
NOTE: Just resting the baking container on top of the non-stick surface will not damage it. Do not use saucepans or plates
- Use only plastic or wooden utensils on non-stick surfaces.
- Adjust heat setting gradually and only as necessary. Cooking foods at too high a temperature can cause them to dry out.
- When grilling fish or chicken breast fillets, tuck extremely thin parts under to prevent overcooking.

## Instructions For Cleaning

**CAUTION: Grill surfaces are hot during use. Allow Grill Plate, Drip Cup, Lid and Grill Base to cool completely before handling and cleaning.**

1. Unplug and allow to cool before disassembling and cleaning. Thoroughly clean all parts after each use.
2. Remove the Temperature Control Probe (DO NOT IMMERSE). Wipe with a damp cloth and dry thoroughly.

**CAUTION: Do not immerse the Temperature Control Probe in water or any other liquid.**

3. Remove the Grill and empty the Drip Cup.
4. Wash the Grill Base, Grill Plate, Drip Cup and Lid with warm, soapy water and a plastic scouring pad. Rinse and dry thoroughly. Do not use steel wool, coarse scouring pads or harsh or abrasive cleaners to clean the Grill parts. If necessary, use a nylon bristle brush to loosen hardened food particles.

**CAUTION: The Temperature Control Probe receptacle must always be completely dry before use. Before inserting Temperature Control Probe in the Receptacle, ensure the interior of the Receptacle is fully dry. To do this, wipe the interior of the Receptacle with a dry cloth or shake out excess water vigorously.**

5. We recommend storing the Grill indoors. If unable to store indoors, always cover Grill with protective cover.
6. Any servicing requiring disassembly other than the above cleaning must be performed by an authorized electrician.



# Suggested Cooking Chart

The following times are meant to be used as guidelines only. Cooking times will vary due to the thickness of the meat being cooked. To be sure that the meat is truly done, use a meat thermometer. If the meat does need more time to cook, simply place the meat back on the Grill for 5 minute increments and check periodically so you don't over cook.

## Grill Chart

1. Preheat the Electric Grill at the desired temperature setting for a minimum of 15 minutes.
2. Place food on Grill. Do not cover grease channel with food.
3. Grill food according to recommended time or until desired doneness. Turn halfway through cooking time, or more often if necessary.
4. Leave the Lid on during cooking to decrease cooking time and keep food moist and juicy.
5. Boneless cuts of meat will grill more evenly and not scratch the non-stick surface.

<b>FOOD</b>	<b>TEMPERATURE</b>	<b>TIME</b>
Bacon	5	10-15 Minutes
Bratwurst	5	25-35 Minutes
Chicken Breast	4	20-30 Minutes
Fish, 1-inch thick	4	20 Minutes
Frankfurters	5	10-20 Minutes
Hamburgers	4	5-15 Minutes
Pork Chops, 1-inch thick	5	20-35 Minutes
Sausage, fresh	4	20-30 Minutes
Steak, 3/4 inch thick	5	5-15 Minutes
Steak, 1/2 inch thick	5	5-10 Minutes
Shish-ka-bobs	5	20-25 Minutes
Shrimp, large	5	10-15 Minutes

# Roasting/Baking Chart

1. Preheat the Electric Grill at the desired temperature setting for a minimum of 15 minutes.
2. Place meat or poultry in a baking container and add 1 cup water or broth.
3. Cover baking container with aluminum foil or glass cover. Using oven mitts, carefully place baking container on the Grill, cover Grill with Lid to keep in moisture.

NOTE: A cooking bag may be used inside a baking container. Follow manufacturer's instructions. Food wrapped in aluminum foil may be placed directly on Grill.

FOOD	AMT.	TEMP	TIME	INTERNAL TEMP
Beef Roast	2-4 lbs.	5	1 1/2-2 1/2 hrs	Medium to Well 160°-170°F (71°-77°C)
Chicken, whole fryer	2-1/2-4 lbs.	5	1 1/4-2 hrs	Well 180°F (82°C)
Fresh Ham	5-7 lbs.	5	1 1/2-2 1/2 hrs	Well 180°F (82°C)
Pork Roast	2-4 lbs.	5	1 1/2-3 hrs	Medium to Well 160°-170°F (71°-77°C)
Baking Potato, (wrap in foil)	1-10	5	1 1/4-1 1/2 hrs	Until done, turn half way through cooking time

**PLEASE NOTE:** The USDA recommends that meats such as beef, pork and lamb should be cooked to an internal temperature of at least 145°F and pork should be cooked to an internal temperature of at least 160°F to be sure any harmful bacteria has been killed. When reheating meats/poultry products, they should also be cooked to an internal temperature of 165°F.

# Recipes

## The Champ's Sausage Without Guilt

Try this sizzling sausage patty that not only tastes good, but is also good for you. Choose ground turkey breast, which is lower in fat than ground turkey containing dark meat and skin. Turkey, especially the light meat, is a good source of niacin, which is an important B vitamin needed to maintain a healthy nervous system. Early symptoms of niacin deficiency that appear in the nervous system are apprehension, irritability, depression, weakness, and loss of memory. To prevent niacin deficiency, include plenty of lean turkey, fish, whole wheat, potatoes, corn flower, eggs, broccoli, tomatoes, and carrots.

2 slightly beaten egg whites  
2/3 cup finely chopped onion  
1/2 cup finely snipped dried apples or  
1 cup finely chopped fresh red Delicious apple  
1/2 cup seasoned bread crumbs  
4 Tbsp. snipped fresh parsley  
1 tsp. sea salt  
1 tsp. ground sage  
1/2 tsp. ground nutmeg  
1/2 tsp. black pepper  
1/4 tsp. cayenne pepper  
1 lb. lean ground turkey breast

- In a medium bowl, combine all ingredients except turkey. Add the ground turkey and mix well.
- Shape the mixture into sixteen to eighteen 2-inch wide patties.
- Preheat the Electric Barbecue Grill on setting 4 for 15 minutes.
- Place sausage on the Electric Barbecue Grill. Cover and cook on setting 4 for 16-17 minutes. Turn and cook another 16-17 minutes or until the meat is no longer pink and the juices run clear.
- Serves 8

This recipe is from "The Healthy Gourmet" (Clarkson Potter) by Cherie Calbom.

## George's Sausage Texas Style

A spicy sausage with true Southwestern zip! These breakfast sausages are great served with a sautéed vegetable or fresh salsa and scrambled eggs. Buy 90% lean ground beef for the least-fat sausage. Ninety percent lean beef has 9 grams of fat with 4 of those grams being saturated fat; whereas 73% lean beef has 18 grams of fat with 7 of the grams being saturated.

2 slightly beaten egg whites  
2/3 cup finely chopped onion  
1/2 cup seasoned bread crumbs  
1/2 cup diced green chili peppers  
2 cloves (large) garlic, finely minced  
4 Tbsp. snipped fresh cilantro  
2 Tbsp. apple cider vinegar  
1 Tbsp. chili powder  
1/2 tsp. sea salt  
1/4 tsp. cayenne pepper  
1 lb. lean ground beef

- In a medium bowl, combine all ingredients except ground beef. Add the ground beef and mix well.
- Shape the mixture into sixteen 3-inch wide patties.
- Preheat the Electric Grill on Setting 4 for 15 minutes.
- Place the patties on the Electric Grill.
- Cover and cook on Setting 4 for 5-6 minutes. Turn and cook for another 5-6 minutes.
- Serves 8

This recipe is from "The Healthy Gourmet" (Clarkson Potter) by Cherie Calbom.

## George Foreman's Power Burger

A flavorful hamburger that we think tastes even better than its all-meat cousin! It pays to eat meals that minimize meat. To reduce saturated fat in a typical burger, you can cut back on the amount of meat and make up for it with plant-based ingredients. Bread crumbs and chopped vegetables have been added in this recipe. You could also try cooked rice, other grains or cereal. In addition, choose whole wheat buns; they typically contain one less fat gram than regular or even reduced-calorie buns.

If you settle for nothing less than a cheeseburger, Swiss cheese is 1 gram lower in fat than Cheddar, American or Monterey Jack with 8 grams of fat versus 9 in each ounce of cheese. However, reduced fat cheeses like Cheddar or Swiss contain half the fat with 4 grams per ounce. Mustard contains 1 gram of fat per tablespoon versus a whopping 11 grams of fat in a tablespoon of mayonnaise.

Top your burger in healthful style with dark, leafy green lettuce, shredded cabbage, fresh cilantro, basil or spinach.

3/4 cup chopped vegetables such as yellow onions,  
green onions, zucchini, parsley (can be sautéed)

3/4 cup seasoned bread crumbs

2-1/4 lbs. lean ground beef

- In a medium-size mixing bowl, combine the vegetables and bread crumbs. Add the ground beef and mix well.
- Shape the mixture into twelve 4-inch wide patties.
- Preheat the Electric Barbecue Grill on Setting 4 for 15 minutes.
- Place the patties on the Electric Barbecue Grill.
- Cover and cook 12-13 minutes. Turn and cook another 12-13 minutes or until the meat is no longer pink and the juices run clear.
- Serves 12

This recipe is from "The Healthy Gourmet" (Clarkson Potter) by Cherie Calbom.

## Grilled Vegetables

12 slices eggplant (or 8 baby eggplants)  
4 small onions  
4 small tomatoes  
2 small zucchini  
8-12 mushrooms  
8 large cloves of garlic, peeled and sliced 1/4" thick  
2/3 cup olive oil  
4 tablespoons Italian seasoning

- Slice all vegetables 1/2 inch thick.
- Brush vegetables and garlic lightly with olive oil.
- Sprinkle Italian seasoning on both sides of vegetables and garlic.
- Preheat the Electric Barbecue Grill on Setting 4 for 15 minutes.
- Place vegetables and garlic on Grill. Cover and cook on Setting 4 for 7-8 minutes. Turn and cook another 10-15 minutes or until desired doneness is achieved.
- Serves 6-8

Serve as an accompaniment to meat and pasta, or stuff them into a piece of pita or French bread for a grilled vegetable sandwich.

## Mustard Lemon Chicken Breasts

4 tablespoons mustard  
4 tablespoons balsamic vinegar  
6 tablespoons lemon juice  
4 cloves garlic, minced  
2 tsp. paprika  
8 6-oz. chicken breast, halved, boneless and skinless

- In a medium non-metal bowl, combine all ingredients except chicken.
- Add chicken breast and let it marinate for at least 1/2 hour in the refrigerator.
- Preheat the Electric Barbecue Grill on Setting 4 for 15 minutes.
- Place chicken on Electric Barbecue Grill. Cover and cook on Setting 4 for 7-8 minutes. Turn and cook another 7-8 minutes.
- Serves 8

## Rosemary Lamb Chops

16 loin lamb chops

4 tsp. chopped fresh rosemary

ground black pepper to taste

- Sprinkle chops with rosemary and pepper.
- Preheat Electric Barbecue Grill on Setting 4 for 15 minutes.
- Place meat on Electric Barbecue Grill. Cover and cook on Setting 4 for 5-6 minutes for medium or 6-7 minutes for well done. Turn and cook another 5-6 minutes for medium or 6-7 minutes for well done.
- Serves 8

# ONE-YEAR LIMITED WARRANTY

This Salton, Inc. product warranty extends to the original consumer purchaser of the product.

**Warranty Duration:** This product is warranted to the original consumer purchaser for a period of one (1) year from the original purchase date.

**Warranty Coverage:** This product is warranted against defective materials or workmanship. This warranty is void if the product has been damaged by accident, in shipment, unreasonable use, misuse, neglect, improper service, commercial use, repairs by unauthorized personnel or other causes not arising out of defects in materials or workmanship. This warranty is effective only if the product is purchased and operated in the USA, and does not extend to any units which have been used in violation of written instructions furnished by Salton, Inc., or to units which have been altered or modified or to damage to products or parts thereof which have had the serial number removed, altered, defaced or rendered illegible.

**Warranty Disclaimers:** This warranty is in lieu of all warranties expressed or implied and no representative or person is authorized to assume for Salton, Inc. any other liability in connection with the sale of our products. There shall be no claims for defects or failure under any theory of tort, contract or commercial law including, but not limited to, negligence, gross negligence, strict liability, breach of warranty and breach of contract. Salton, Inc. is not responsible or liable for indirect, special or consequential damages arising out of or in connections with the use or performance of the product or other damages with respect to loss of property, or loss of revenues or profit.

**Warranty Performance:** During the above one-year warranty period, a product with a defect will be either repaired or replaced with a reconditioned comparable model (at Salton, Inc.'s option) when the product is returned to the Salton, Inc. facility. The repaired or replacement product will be in warranty for the balance of the one-year warranty period and an additional one-month period. No charge will be made for such repair or replacement.

## Service and Repair

If service is required, you should first call toll-free 1-800-233-9054 **between the hours of 8:00 am and 5:00 pm Central Standard Time** and ask for CONSUMER SERVICE. Please refer to model GGR57 when you call.

**In-Warranty Service:** For an appliance covered under the warranty period, no charge is made for service or postage. Contact Consumer Service for return authorization.

**Out-of-Warranty Service:** A flat rate charge by model is made for out-of-warranty service. Please include \$20.00 (U.S.) for return shipping and handling.

Salton, Inc. cannot assume responsibility for loss or damage during incoming shipment. For your protection, carefully package the product for shipment and insure it with the carrier. Be sure to enclose the following items with your appliance: any accessories related to your problem; your full name and return address and daytime phone number; a note describing the problem you experienced; **a copy of your sales receipt or other proof of purchase to determine warranty status.** C.O.D. shipments cannot be accepted.

Return the appliance to:

ATTN: Repair Department, Salton, Inc.  
708 South Missouri St. Macon, MO 63552

## For more information on Salton Inc. products:

visit our website: [www.salton-maxim.com](http://www.salton-maxim.com), or you can email us at: [salton@saltonusa.com](mailto:salton@saltonusa.com)

Printed in China

© 2001 Salton, Inc.

P/N 60652