

OWNER'S MANUAL

Model No. GV12

GEORGE FOREMAN™



IMPORTANT SAFEGUARDS

When using electrical appliances, basic safety precautions should always be followed, including the following:

1. Read all instructions before using appliance.
2. Do not touch hot surfaces. Use handles or knobs and oven mitts or pot holders.
3. To protect against electric shock do not immerse cord, plugs, or body of unit in water or other liquid.
4. Close supervision is necessary when any appliance is used near children.
5. This appliance is not for use by children.
6. Unplug from outlet when not in use and before cleaning. Allow to cool before putting on or taking off parts, and before cleaning the appliance.
7. Do not operate any appliance with a damaged cord or plug or after the appliance malfunctions, or has been dropped or damaged in any manner. Contact consumer service for return authorization, examination, repair or adjustment.
8. The use of accessory attachments not recommended by the appliance manufacturer may cause injuries.
9. Do not use outdoors or while standing in a damp area.
10. Do not let cord hang over edge of table or counter, or touch hot surfaces.
11. Do not place on or near a hot gas or electric burner, or in a heated oven.
12. To disconnect, press ON/OFF button to OFF, then grasp plug and remove from wall outlet.
13. Do not use appliance for other than intended use.
14. Do not move the Contact Roaster containing hot oil or other hot liquids. Allow liquid to cool before removing and emptying drip tray.

SAVE THESE INSTRUCTIONS

THIS APPLIANCE IS FOR HOUSEHOLD USE ONLY

Additional Important Safeguards

1. **CAUTION:** *This appliance generates heat and escaping steam during use. Proper precautions must be taken to prevent the risk of burns, fires or other damage to persons or property.*
2. All users of this appliance must read and understand this Owner's Manual before operating or cleaning this appliance.
3. The cord to this appliance should be plugged into a 120V AC electrical outlet only.
4. When using this appliance, provide adequate air space above and on all sides for air circulation. Do not allow this appliance to touch curtains, wall coverings, clothing, dish towels or other flammable materials during use. Do not put anything on top of the oven when it is hot. Make sure the counter top material can withstand the heat from the Contact Roaster.
5. Do not use plastic dishes inside the Contact Roaster.
6. Do not leave this appliance unattended during use. This unit does NOT shut off by itself.
7. This appliance generates steam—do not operate in open position.
8. If this appliance begins to malfunction during use, immediately switch off and unplug cord from outlet. Do not use or attempt to repair the malfunctioning appliance.
9. **Using pot holder, hold the top cover (Lid) open while placing or removing food or Baking Pan to prevent accidental closing and injury.**
10. Always open the Lid before removing Baking Pan.
11. **CAUTION: Hot surfaces.**

Polarized Plug

This appliance has a **polarized plug** (one blade is wider than the other). To reduce the risk of electric shock, this plug will fit into a polarized outlet only one way. If the plug does not fit fully into the outlet, reverse the plug. If it still does not fit, contact a qualified electrician. Do not attempt to modify the plug in any way.

Short Cord Instructions

A short power-supply cord is provided to reduce the risk resulting from becoming entangled in or tripping over a longer cord. Extension cords are available and may be used if care is exercised in their use.

If an extension cord is used, (1) the marked electrical rating of the extension cord should be at least as great as the electrical rating of the appliance, and (2) the cord should be arranged so that it will not drape over the counter top or table top where it can be pulled on by children or tripped over unintentionally.

Electric Power

If the electric circuit is overloaded with other appliances, your appliance may not operate properly. It should be operated on a separate electrical circuit from other appliances.

Note: If a power interruption occurs, the Contact Roaster will return to preheat and the power will still be "on".

CAUTION: To prevent Plasticizers to migrate from the finish of the counter top or table top or other furniture, place **NON-PLASTIC** coasters or placemats between the appliance and the finish of the counter top or table top.

Failure to do so may cause the finish to darken, permanent blemishes may occur or stains can appear.

Getting To Know Your GV12 Lean Mean Contact Roasting Machine

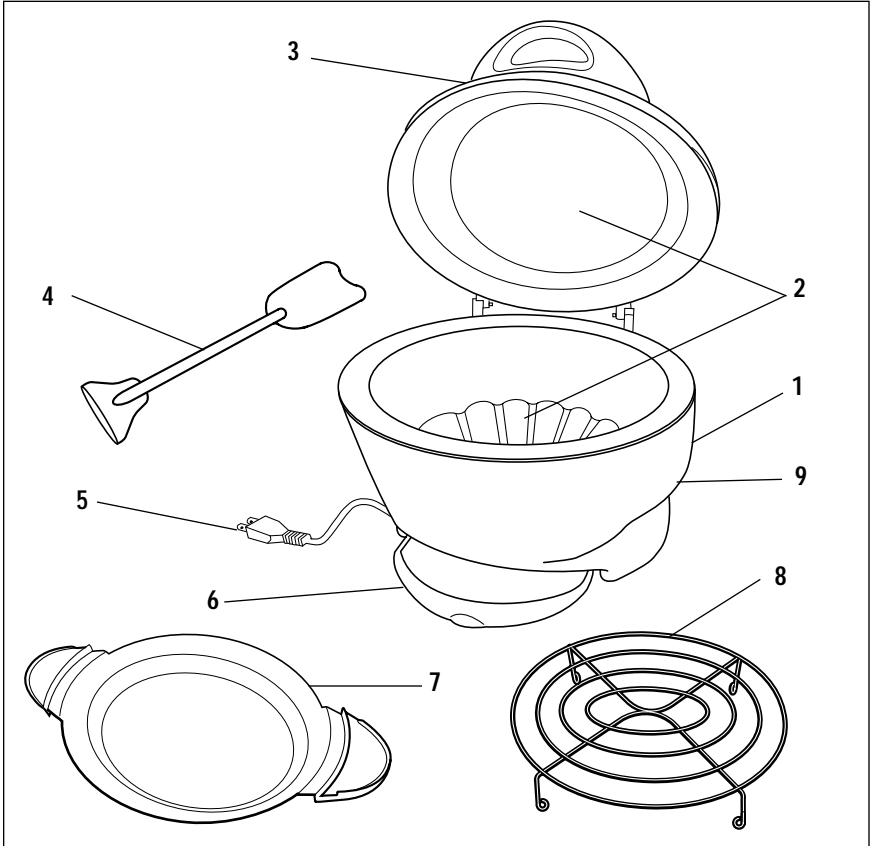

1. Roasting Machine Body
2. Heating Plates
3. Lid with Handle
4. Cleaning Utensil (P/N 21972)
5. Power-Supply Cord with Polarized Plug
6. Drip Tray (P/N 21973)
7. Baking Pan (P/N 21974)
8. Wire Rack (P/N 21975)
9. Cord Wrap Area

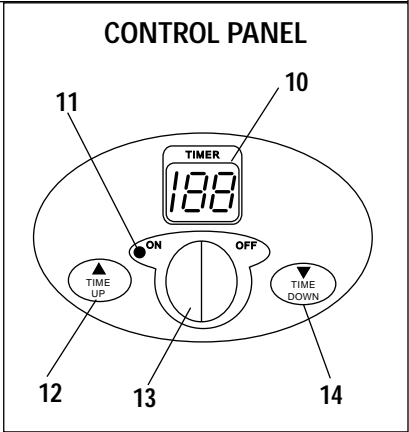

10. Variable Timer Display (LED)
11. Power On Indicator
12. Variable Timer Up Button
13. ON-OFF Button
14. Variable Timer Down Button

How To Use George Foreman's Lean Mean Contact Roasting Machine

1. Place the Contact Roaster on a stable and level surface, such as a counter top. Wipe the Heating Plates with a damp cloth to remove all dust. Make sure the ON/OFF Button is in the "OFF" position.
2. Make sure the size of meats, poultry or other foods fit into the Contact Roaster before preheating. Place the Wire Rack into the Roaster if desired. The Wire Rack should be used, in either the upright or inverted position when cooking meats that require longer cooking times or to steam vegetables.
3. **To preheat:** Close the Lid and plug cord into a 120V AC polarized outlet. Press the ON/OFF Button to the "ON" position. The Power On Indicator will illuminate. The Variable Timer Display will alternately flash "ph" and "5" indicating the start of the 5 minute preheat countdown. When preheat is complete the unit will beep 4 times and the Timer Display will flash "ph". If cooking time is not entered the unit will beep periodically as a reminder that the unit is ON and ready to cook.
4. Use a pot holder or oven mitt to carefully open the Lid.
5. Slide the Drip Tray under the front of the unit.
6. Wear oven mitts and use plastic or wooden utensils to carefully place food into the Contact Roaster. Always use plastic or wooden utensils to avoid scratching the non-stick surface. Never use metal tongs, forks or knives as these can damage the non-stick coating. Use oven mitts when inserting Baking Pan into the hot Contact Roaster. Use the Baking Pan to cook foods containing liquids.
7. Close the Lid. Set the Timer by pressing the UP or DOWN arrows to obtain your desired cook time. (Please note that the Contact Roaster will accept a maximum of 150 minutes.) The Display will show the set time. See the Suggested Cooking Chart on the following page and the Recipe Section for specific details and suggestions. **CAUTION: Do not preheat or cook with the Lid in the open position.**
8. Allow the food to cook for the set time. **Do not leave appliance unattended during use!** During roasting, the Timer Display will begin counting down. When the set time has elapsed the unit will beep 4 times. The Display will alternately flash "00" and "on" as a reminder that the power is still on. The Power On Indicator will remain on until the ON/OFF Button is pressed to the "OFF" position. If the unit is not turned off, the unit will beep twice every 5 minutes as a reminder that the unit is still on.
9. After the desired amount of time, the food should be done. Using a pot holder, carefully and slowly raise the Lid to allow steam to escape at the sides before fully opening. Check food for doneness using a cooking thermometer. If necessary, reset the Timer for additional time and check periodically to avoid over cooking.
10. Press the ON/OFF Button to the "OFF" position. Disconnect plug from wall outlet. **CAUTION: To avoid any sparks at the outlet while disconnecting plug, make sure the "Power On Indicator" is off (not illuminated) before disconnecting the plug from the outlet.**
11. Wear oven mitts and carefully remove the food using plastic or wooden utensils. Always use oven mitts when removing Baking Pan and place on a heat resistant surface.
12. When cool, the Drip Tray may be removed and emptied. **Be sure the liquid has cooled before removing Drip Tray.**
13. Thoroughly clean the Contact Roaster after each use. Refer to User Maintenance Instructions for details.

Cooking Chart

Preheat the Contact Roaster before using to roast the following foods. The following times are meant to be used as guidelines only. Times will vary due to the cut or thickness of the meat or poultry being cooked. To be sure that the food is truly done, use a cooking thermometer. If the food does need more time to cook, reset the timer and check periodically so you do not over cook.

FOOD & QUANTITY	FOOD PLACEMENT	WEIGHT	COOKING TIME	INTERNAL FOOD TEMPERATURE
POULTRY				
Chicken, whole	Heating Plate	2 ½ - 3 lb.	45-75 min.	180°F
Chicken, whole	Heating Plate	4 - 5 lb.	60-75 min.	180°F
Rock Cornish Game Hens (6)	Inverted Wire Rack	20 oz each	60-90 min.	180°F
Turkey	Inverted Wire Rack	12 lb.	115-130 min.	180°F
BEEF				
Tenderloin	Inverted Wire Rack	2 - 3 lb.	60-90 min.	145° -170°F
Ribeye Roast	Inverted Wire Rack	5 - 6 lb.	150-170 min.	145° -170°F
Sirloin Roast	Wire Rack	4 - 5 lb.	110-150 min.	145° -170°F
PORK				
Tenderloin	Wire Rack	2 lb.	60-75 min.	160° -170°F
Center Loin Roast	Inverted Wire Rack	4 - 5 lb.	160-180 min.	160° -170°F
LAMB				
Leg, semi boneless	Wire Rack	4 - 5 lb.	130-175 min.	145° -170°F
MISCELLANEOUS				
Baked Potatoes, 6-8, wrapped in foil	Inverted Wire Rack	10 - 12 oz. each	130-160 min.	Cook until fork tender
Baked Potatoes, 8, wrapped in foil	Inverted Wire Rack	6 - 8 oz. each	80-100 min.	Cook until fork tender

PLEASE NOTE: The USDA recommends that meats such as beef and lamb, etc. should be cooked to an internal temperature of 145°-170°F. Pork should be cooked to an internal temperature of 160°-170°F and poultry products should be cooked to an internal temperature of 170°F - 180°F to be sure any harmful bacteria has been killed. When reheating meat/poultry products, they should also be cooked to an internal temperature of at least 165°F.

Frozen Convenience Foods Cooking Guide

Most frozen convenience foods such as small pizza, breaded stuffed jalapeno poppers, taquitos, potato skins, potato patties, and hot wings can be cooked in the Contact Roaster. Preheat the Contact Roaster and distribute the food evenly onto the Heating Plates in a single layer. Remove crumbs and/or ice crystals from food before placing on the hot heating plates. Set the Timer for package time, turn food halfway during cooking if necessary for even browning. Watch foods closely to prevent over-cooking. If the food needs more time to cook, reset the Timer and check periodically so you do not over-cook the food.

Frozen Vegetables Cooking Guide

Frozen vegetables such as Brussels sprouts, mixed vegetables, and green beans can be cooked in the Contact Roaster. DO NOT PREHEAT the Contact Roaster. Add a 16 ounce package of frozen vegetables to the Baking Pan and add the amount of water called for on the package, or at least 1/4 cup. Insert the Baking Pan into the Contact Roaster. Close the Lid and set the Timer for 45 minutes. Check for doneness and continue cooking if necessary.

Steamed Rice Cooking Guide

Any type of rice such as white, brown or flavored can be cooked in the Contact Roaster. DO NOT PREHEAT the Contact Roaster. Coat Baking Pan with non-stick spray, add 1 cup of raw rice and all the other ingredients called for on the package plus an additional 1/2 cup of water. Insert the Baking Pan into the Contact Roaster. Close the Lid and set the Timer for 45 minutes for white rice or flavored rice, and 75 minutes for brown rice. When the Timer reads 10 minutes remaining, open the Lid and quickly stir rice. Lower the Lid and resume cooking. Check for doneness and continue cooking if necessary.

Steamed Potatoes and Squash Cooking Guide

Vegetables with a skin such as 8-10 ounce potatoes, sweet potatoes, zucchini, yellow, acorn, butternut and spaghetti squash can be cooked in the Contact Roaster. Cut the potato or squash in half and remove seeds if necessary. DO NOT PREHEAT the Contact Roaster. Insert the Baking Pan into the Contact Roaster. Add two cups of water to the Baking Pan and place the Wire Rack inside the Baking Pan. Lay the potato or squash on the Wire Rack, skin side up, to fill the Wire Rack. Close the Lid and set the Timer for 75 minutes. Check for doneness and continue baking if necessary.

User Maintenance Instructions

This appliance requires little maintenance. It contains no user serviceable parts. Do not try to repair it yourself. Contact a qualified appliance repair technician if the product requires servicing.

CAUTION: To avoid accidental burns, allow the Contact Roaster to cool thoroughly before cleaning.

1. Before cleaning, unplug the Contact Roaster from the wall outlet and allow to cool for approximately 30 minutes.
2. **Inside cleaning:** Place the Drip Tray under the front of the Contact Roaster. Wipe the plates with absorbent paper towel or a sponge. Run off will drip into the Drip Tray. If necessary, use the contoured plastic Cleaning Utensil to scrape off any excess fat or food particles from the Heating Plate. The opposite end of the Cleaning Utensil can be used to push any accumulated residue through the opening and into the Drip Tray.
3. **Stubborn build-up:** Use a non-metallic scrubbing pad to clean the plates.
4. Empty the Drip Tray. Wash the Baking Pan, Wire Rack, Drip Tray and Cleaning Utensil in warm, soapy water. Rinse and dry thoroughly.
5. **Outside cleaning:** Wipe with a warm, damp sponge and dry with a soft, dry cloth.
6. Do not use steel wool, scouring pads, or abrasive cleaners on any part of the Contact Roaster.
7. **DO NOT IMMERSE IN WATER OR OTHER LIQUID.**
8. Make sure to hold the top cover (Lid) by hand while cleaning to prevent accidental closing and injury.
9. Store the cord by wrapping around Cord Wrap Area only when Contact Roaster is fully cooled.

Recipes

NOTE: For all recipes, please remember to place Drip Tray under the front of the Contact Roaster to catch drippings from the cooking process.

NOTE: For recipes that do NOT require preheating the Contact Roaster – place food in the unit, close Lid and press ON. Even though the unit automatically goes into Preheat mode – simply adjust to the desired cooking time.

Breakfast Casserole

6 slices whole wheat bread, cubed
1 lb. Canadian bacon, chopped
2 cups pineapple tidbits
1 1/2 cups reduced-fat shredded cheddar cheese
1 1/2 cups cholesterol-free egg product
1 1/2 cups skim milk
1/2 tsp. salt
1/2 tsp. white pepper

- Preheat the Contact Roaster.
- Coat the Baking Pan with non-stick spray and add the bread cubes.
- Layer the Canadian bacon over bread followed by pineapple and then sprinkle cheese on top.
- Mix the cholesterol-free egg product, skim milk, salt and pepper. Pour over the bread mixture.
- Using oven mitts, insert the Baking Pan into the Contact Roaster. Close the Lid and set the Timer for 45 minutes or bake until eggs are set.
- Yield: Serves 8

Recipes (Cont.)

Garlic and Tarragon Roasted Chicken

4-5 lb. whole chicken
3 Tbsp. chopped tarragon
4 Tbsp. melted butter
1 Tbsp. minced garlic
salt and pepper to taste
1 lemon, sliced
1 Tbsp. olive oil

- Preheat the Contact Roaster.
- Mix the tarragon, butter, garlic, salt and pepper in a bowl. Pull the skin away from the chicken and rub the mixture on the meat. Pull skin back over the meat.
- Place the lemon slices inside the chicken cavity and then rub the olive oil on the skin.
- Using oven mitts and a plastic or wooden utensil, place the chicken into the Contact Roaster and set the Timer for 75 minutes. Check for doneness and continue roasting if necessary.
- Yield: Serves 4-6

Roasted Chicken with Stuffing

4-5 lb. whole chicken
1 1/2 Tbsp. olive oil
1 Tbsp. Italian seasoning
2 10 3/4-oz. can reduced fat cream of mushroom soup
2 cups water
12-oz. stuffing mix

- Preheat the Contact Roaster.
- Coat the Baking Pan with non-stick spray. Rub the olive oil over the chicken and sprinkle the Italian seasoning on top of the skin. Place into the Baking Pan.
- Mix the mushroom soup and water together. Stir in the dry stuffing mix. Arrange around the chicken in the Baking Pan.
- Using oven mitts, insert the Baking Pan into the Contact Roaster and set the Timer for 100 minutes. Check for doneness and continue roasting if necessary.
- Yield: Serves 4

Fruit Stuffed Roast Pork with Sweet Potatoes

4-5 lb. center loin pork roast, tied
1 cup dried apples
3/4 cup raisins
6 medium sweet potatoes, cut in 2 inch pieces
1 1/2 Tbsp. crushed thyme
salt and pepper to taste

- Preheat the Contact Roaster with inverted rack.
- Push apples and raisins down between two pieces of roast.
- Rub the pork roast with thyme, salt and pepper.
- Using oven mitts and a plastic or wooden utensil, place the meat into the Contact Roaster and set the Timer for 45 minutes. When the timer goes off, turn the roast over and add the sweet potatoes. Set the Timer for an additional 135 minutes. Check for doneness and continue roasting if necessary.
- Yield: Serves 10-12

Recipes (Cont.)

Beef Stew

2 Tbsp. low-fat butter
2 small onion, chopped
4 cloves garlic, minced
2 lb. stew meat, cut into 1-inch cubes
4 small carrots, cut into 1/2-inch slices
6 small potatoes, cut into 1-inch cubes
1/2 cup chopped prunes
1/4 cup all-purpose flour
2 bay leaves
2 tsp. dried thyme leaves
2 Tbsp. chopped parsley
2 1/4 cups beef broth

- Place the Baking Pan into the Contact Roaster and add the low-fat butter. Close the Lid and preheat to melt the butter.
- At the end of the preheat time, add the onions. Close the Lid and cook 10 minutes.
- Stir in the garlic, close the lid and cook 2 minutes.
- Combine remaining ingredients and stir into onion mixture. Close the Lid and set the Timer for 105 minutes. Check for tenderness and continue baking if necessary.
- Yield: Serves 8

Roast Beef

4-5 lb. sirloin beef roast
4 tsp. all-purpose flour
2 Tbsp. dry mustard
salt and pepper to taste

- Insert the Wire Rack and preheat the Contact Roaster.
- Mix the flour, mustard, salt and pepper together and sprinkle over the roast.
- Using oven mitts and a plastic or wooden utensil, place the meat into the Contact Roaster and set the Timer for 110 - 150 minutes. Check for doneness and continue roasting if necessary.
- Yield: Serves 12-16

Marinated Roast Beef with Vegetables

2 lbs. tenderloin beef roast
1 lb. carrots, cut in half and again lengthwise
16 small new potatoes, cut in half

Marinade

1 cup beef broth
1/2 cup olive oil
1/4 cup lemon juice
1 tsp. Tabasco pepper sauce
1/2 cup minced onion
2 cloves garlic, minced
1 tsp. salt
1 tsp. dried basil leaves
1 tsp. dried tarragon leaves
1 tsp. prepared mustard

- Place the meat, carrots and potatoes in a sturdy zip lock bag.
- Mix all marinade ingredients together and pour over the meat and vegetables. Marinate in refrigerator at least 3 hours, turning occasionally.
- Preheat the Contact Roaster with inverted Wire Rack.
- Using a large slotted spoon, add the meat and vegetables to the Contact Roaster.
- Close the Lid and set the Timer for 60 minutes. Check for doneness and continue roasting if necessary.
- Yield: Serves 6-8

Recipes (Cont.)

Sauerkraut and Sausage Casserole

- 2 Tbsp. low-fat butter
- 1 cup chopped red onion
- 1 cup chopped green pepper
- 2 14 oz. smoked turkey sausages, cut into 1/2-inch slices
- 3 14-oz. cans Bavarian style sauerkraut, undrained

- Place the Baking Pan into the Contact Roaster and add the low-fat butter. Close the Lid and preheat to melt the butter.
- At the end of the preheat time, add the red onions and green peppers. Close the Lid and set the Timer for 10 minutes.
- Stir in the sausage and sauerkraut. Close the Lid and set the Timer for 40 minutes. Check for doneness and continue baking if necessary.
- Yield: Serves 6-8

Turkey and Vegetable Loaf

- 1 cup quick oats
- 2 1/2 lbs. ground turkey breast
- 1 cup finely chopped celery
- 1/4 cup finely chopped green pepper
- 1/4 cup finely chopped red onion
- 1 cup finely chopped carrots
- 2 Tbsp. steak sauce
- 1/2 cup cholesterol-free egg product
- 1 15-oz. can tomato sauce, divided
- salt and pepper to taste

- Preheat the Contact Roaster.
- Combine the oats, ground turkey, celery, green pepper, red onion, carrot, steak sauce, cholesterol-free egg product, and 1/2 of the tomato sauce.
- Coat the Baking Pan with non-stick spray and press in the meat mixture. Pour the remaining tomato sauce over the meat loaf.
- Using oven mitts, insert the Baking Pan into the Contact Roaster. Close the Lid and set the Timer for 75 minutes. Check for doneness and continue baking if necessary.
- Yield: Serves 8

Salmon Loaf

2 15-oz. cans salmon, drained
1 cup cholesterol-free egg product
1 cup skim milk
2 Tbsp. onion flakes
2 tsp. lemon juice
2 tsp. lemon pepper seasoning
2 tsp. Worcestershire® sauce
1 tsp. dry mustard
1/2 cup mayonnaise
6 slices whole wheat bread, crumbled
1 Tbsp. paprika

- Preheat the Contact Roaster.
- Combine all the ingredients except the paprika.
- Coat the Baking Pan with non-stick spray and press in the salmon mixture. Sprinkle the top with paprika.
- Using oven mitts, insert the Baking Pan into the Contact Roaster. Close the Lid and set the Timer for 45 minutes. Check for doneness and continue baking if necessary.
- Yield: Serves 8

Recipes (Cont.)

Ginger Salmon Steaks

4 10-oz. salmon steaks, 1-inch thick
4 Tbsp. vegetable oil
4 green onions, thinly sliced
2 Tbsp. minced ginger
2 cloves garlic, minced
pinch red pepper
2 Tbsp. lemon juice
2 tsp. soy sauce

- Place the Baking Pan into the Contact Roaster and add the vegetable oil. Close the Lid and preheat to heat the oil.
- At the end of the preheat time, add the green onions. Close the Lid and set the Timer for 10 minutes. Stir in ginger, garlic and red pepper, close the Lid and set the Timer for 3 minutes. Stir in the lemon juice and soy sauce.
- Carefully place the salmon steaks in the onion mixture and then turn over to coat both sides. Close the Lid and set the Timer for 30 minutes. Check for doneness and continue baking if necessary.
- Yield: Serves 4

Alaskan Halibut with Crumb Topping

2 lb. Alaskan Halibut, 1-inch thick
4 tsp. lemon juice
1 cup seasoned bread crumbs
1/4 cup grated Parmesan cheese
4 tsp. chopped parsley
1/2 cup no-fat mayonnaise

- Preheat the Contact Roaster.
- Coat the Baking Pan with non-stick spray and add the fillets, tucking under the tail sections to make it the same thickness. Brush the top of fillets with the lemon juice.
- Combine the bread crumbs, Parmesan cheese, parsley and the mayonnaise. Spread over the fillets.
- Using oven mitts, insert the Baking Pan into the Contact Roaster. Close the Lid and set the Timer for 30 minutes. Check for doneness and continue baking if necessary.
- Yield: Serves 6-8

Fruit Pizza

2 6.5 oz. packages pizza crust mix
3 Tbsp. strawberry preserves
1/3 cup diced apples, peeled
1/3 cup diced pears, peeled
2 kiwis, peeled and sliced

- **DO NOT** preheat the Contact Roaster.
- Mix the pizza crust according to package directions.
- Spray the bottom of the Contact Roaster with non-stick spray. Press the dough into the bottom and up the sides 1-inch of the cold Contact Roaster.
- Spread the crust with preserves, then top with remaining ingredients.
- Close the Lid. Set the Timer for 25 minutes. Check for doneness and continue baking if necessary.
- Yield: Serves 8

Fat-Free Chocolate Cake

2 cups sugar
2 cups all-purpose flour
1 cup cocoa
2 tsp. baking soda
2 2/3 cups applesauce
8 egg whites
4 tsp. vanilla

Topping

2 Tbsp. powdered sugar

- Preheat the Contact Roaster.
- Coat the Baking Pan with non-stick spray.
- Sift the sugar, flour, cocoa and baking soda together in a bowl. Use a whisk to beat the applesauce, egg whites and vanilla together. Combine the egg white mixture into the flour mixture, do not over mix. Pour into the Baking Pan.
- Using oven mitts, insert the Baking Pan into the Contact Roaster. Close the Lid and set the Timer for 45 minutes. Check for doneness and continue baking if necessary. Sprinkle with powdered sugar.
- Yield: Serves 8

Recipes (Cont.)

Apple Cake with Butter Sauce

2 cups self-rising flour
1 cup whole wheat flour
1 cup brown sugar
1 Tbsp. cinnamon
1 cup applesauce
1 1/2 cups cholesterol-free egg product
1 cup skim milk
2 tsp. lemon rind
1 cup raisins
1 cup chopped walnuts
2 baking apples, peeled and sliced

Butter Sauce

1/2 cup brown sugar
1/2 cup white sugar
1 Tbsp. all purpose flour
1/2 cup half & half
1/2 cup butter
1 tsp. vanilla

- Preheat the Contact Roaster.
- Coat the Baking Pan with non-stick spray.
- Sift the self-rising flour, whole wheat flour, brown sugar and cinnamon together in a bowl.
- Stir the applesauce, egg product and milk together then combine with the flour mixture. Stir in the lemon rind, raisins, walnuts and apples. Pour into the Baking Pan.
- Using oven mitts, insert the Baking Pan into the Contact Roaster. Close the Lid and set the Timer for 65 minutes. Check for doneness and continue baking if necessary.
- Mix all Butter Sauce ingredients and bring to a boil for one minute. Cool slightly before pouring over individual servings of cooked apple cake.
- Yield: Serves 8

LIMITED ONE YEAR WARRANTY

Warranty: This George Foreman™ product is warranted by Salton, Inc. to be free from defects in materials or workmanship for a period of (1) year from the original purchase date. This product warranty covers only the original consumer purchaser of the product.

Warranty Coverage: This warranty is void if the product has been damaged by accident in shipment, unreasonable use, misuse, neglect, improper service, commercial use, repairs by unauthorized personnel, normal wear and tear, improper assembly, installation or maintenance abuse or other causes not arising out of defects in materials or workmanship. This warranty is effective only if the product is purchased and operated in the USA, and does not extend to any units which have been used in violation of written instructions furnished with the product or to units which have been altered or modified or to damage to products or parts thereof which have had the serial number removed, altered, defaced or rendered illegible.

Implied Warranties: ANY IMPLIED WARRANTIES WHICH THE PURCHASER MAY HAVE ARE LIMITED IN DURATION TO ONE (1) YEAR FROM THE DATE OF PURCHASE. Some states do not allow limitations on how long an implied warranty lasts, so the above limitation may not apply to you.

Warranty Performance: During the above one-year warranty period, a product with a defect will be either repaired or replaced with a reconditioned comparable model (at our option) when the product is returned to the Repair Center, or the purchase price refunded. The repaired or replacement product will be in warranty for the balance of the one-year warranty period and an additional one-month period. No charge will be made for such repair or replacement.

Service and Repair: Should the appliance malfunction, you should first call toll-free 1 (800) 937-3883 between the hours of 9:00 am and 5:00 pm Central Standard Time and ask for CONSUMER SERVICE stating that you are a consumer with a problem. Please refer to model number GV12 when you call.

In-Warranty Service (USA): For an appliance covered under the warranty period, no charge is made for service or postage. Call for return authorization (1 800 937-3883).

Out-of-Warranty Service: A flat rate charge by model is made for out-of-warranty service. Include \$12.00 (U.S.) for return shipping and handling. We will notify you by mail of the amount of the charge for service and require you to pay in advance for the repair or replacement.

For Products Purchased in the USA, but Used in Canada: You may return the product insured, packaged with sufficient protection, and postage and insurance prepaid to the USA address listed below. Please note that all customs duty / brokerage fees, if any, must be paid by you and we will require you to pay the cost of customs duty / brokerage fees to us in advance of our performing any service.

Risk During Shipment: We cannot assume responsibility for loss or damage during incoming shipment. For your protection, carefully package the product for shipment and insure it with the carrier. Be sure to enclose the following items with your appliance: any accessories related to your problem, your full return address and daytime phone number, a note describing the problem you experienced, a copy of your sales receipt or other proof of purchase to determine warranty status. C.O.D. shipments cannot be accepted.

To return the appliance, ship to:

Attn: Repair Center
Salton, Inc.
708 South Missouri Street
Macon, MO 63552

To contact us, please write to, call, or email:

Salton, Inc.
P.O. Box 1526
Columbia, MO 65205-1526
1 800 937-3883
Email: Salton@Saltonusa.com

Limitation of Remedies: No representative or person is authorized to assume for Salton, Inc. any other liability in connection with the sale of our products. There shall be no claims for defects or failure of performance or product failure under any theory of tort, contract or commercial law including, but not limited to negligence, gross negligence, strict liability, breach of warranty and breach of contract. Repair, replacement or refund shall be the sole remedy of the purchaser under this warranty, and **in no event shall Salton be liable for any incidental or consequential damages, losses or expenses.** Some states do not allow the exclusion or limitation of incidental or consequential damages, so the above limitation or exclusion may not apply to you.

Legal Rights: This warranty gives you specific legal rights, and you may also have other rights which vary from state to state.

George Foreman™ is a trademark of Salton, Inc.

For more information on Salton products: Visit our website: <http://www.eSalton.com>

© 2002 Salton, Inc.
All Rights Reserved™

P/N 61159
Printed in China