

PASTA & BEYOND™

MEAT GRINDER RECIPES



Recipes, tips, and ideas for home cooks who love flavor

PASTA & BEYOND™

TABLE OF CONTENTS

QUICK START GUIDE.....	4
ASSEMBLING THE MEAT GRINDER HOUSING	5
MEATLOAF.....	6
MAPLE BREAKFAST SAUSAGE PATTIES.....	8
MUSHROOM SWISS BURGERS.....	10

VEGETABLE BURGERS.....	12
POTATO PANCAKES.....	13
SALMON BURGERS.....	14
VEGETABLE HASH.....	16
CORNED BEEF HASH.....	17
FENNEL SAUSAGE.....	17
GROUND CHICKEN CHILI.....	18

PASTA & BEYOND™

Quick Start Guide

See owner's manual for complete instructions and important safety information before using this product.

IMPORTANT: Unpack all parts from the box and remove any clear or blue protective film on the components. Wash with warm, soapy water before first use (only select accessories are dishwasher safe).

STEP 1: Assemble the appliance in Meat Grinder Mode, as shown. Be sure to remove the black storage tray from the Basic Unit Housing and replace it with the Food & Pulp Collector.

STEP 2: Press the Power Button to turn the appliance on.

STEP 3: Press the Forward Button to grind clockwise for 6 minutes. Press the Start/Pause Button at any time to pause the grinding process.

TIP: Cut meat into small cubes or strips to allow for an easier feed into the grinder and to reduce the risk of blockage.



ASSEMBLING THE MEAT GRINDER HOUSING

MEAT GRINDER PARTS

A BASIC UNIT HOUSING

K CHUTE/TRAY

L NARROW PUSHER

J GRINDER HOUSING

M AUGER

N GRINDER BLADE

O GRINDER PLATE

P EXTRUSION CAP

1. Attach the Grinder Housing (J) by pushing it into the matching slots on the Basic Unit Housing (A). See notes in the "Main Unit Housing Backplate" section of the instruction book for assembly.
2. Slide the Auger (M) through the Grinder Housing into the shaft portal in the Basic Unit Housing.
3. Fit the Grinder Blade (N) in place on the front of the Auger shaft. Face the Grinder Blade with the sharp edges facing toward the Grinder Plate (O). Fit the Grinder Plate to the tip of the Auger shaft and secure in place by setting the Grinder Plate tabs into the slots on the front of the Grinder Housing.
4. Secure everything in place by screwing the Extrusion Cap (P) on the threads on front of the Grinder Housing.
5. Remove the black storage tray from the Basic Unit Housing and replace it with the Food & Pulp Collector when grinding meat.
6. Use the Pusher (L) to feed meat into the grinder.

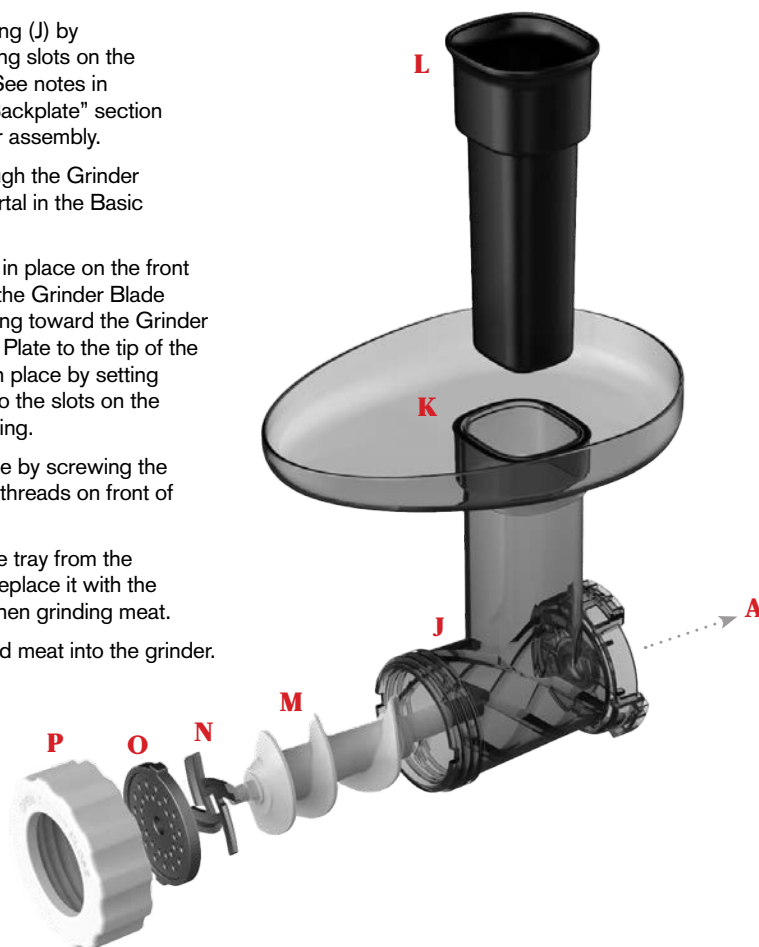

Meatloaf

SERVES 4

INGREDIENTS

¾ lb beef chuck, cubed
¾ lb pork butt, cubed
¾ lb veal stew meat
1 onion, cut into 8 pieces
4 eggs
6 slices whole wheat bread
3 tbsp. yellow mustard
⅓ cup barbeque sauce
3 tbsp. Worcestershire sauce
2 tsp. salt
1 tsp. ground black pepper
1 green pepper, sliced
¼ cup ketchup

DIRECTIONS

- 1.** In a bowl, toss all the meat to mix. Freeze the meat for 1 hour before grinding.
- 2.** With the Meat Grinder Housing attached to the Pasta & Beyond, press the Power Button and then the Forward Button. Grind the meat.
- 3.** In a large bowl, add all the ingredients except the green pepper and ketchup. Mix well and then divide the mixture into two loaf pans.
- 4.** Preheat the oven to 375° F/191° C.
- 5.** Brush the top of the meatloaf with the ketchup and top with the green pepper slices. Cook in the oven until an instant-read thermometer inserted into the meatloaf reads 155° F/68° C (about 1 hour).

NOTE: Freeze meat to keep firm and cold during grinding. Do not let meat get hard.





Maple Breakfast Sausage Patties

SERVES 4–6

INGREDIENTS

1 ½ lb pork butt, cubed
1 tsp. ground sage
1 tsp. ground thyme
¼ tsp. ground cloves
1 tsp. sea salt
1 tsp. ground black pepper
2 tbsp. maple syrup
oil, for pan frying

DIRECTIONS

- 1.** In a bowl, combine all the ingredients and mix together. Freeze for 1 hour before grinding.
- 2.** With the Meat Grinder Housing attached to the Pasta & Beyond, press the Power Button and then the Forward Button. Grind the meat.
- 3.** Form the meat into 3-oz patties.
- 4.** On the stove top, pan sear the patties on each side in a small amount of oil until golden and fully cooked.

NOTE: Freeze meat to keep firm and cold during grinding. Do not let meat get hard.

Mushroom Swiss Burgers

SERVES 6

INGREDIENTS

1 ½ lb beef chuck, cubed
1 tsp. salt
1 tsp. ground black pepper
8 oz Swiss cheese, cubed
6 baby belle or cremini mushrooms, cleaned & trimmed
1 shallot
2 tbsp. steak sauce

DIRECTIONS

1. Season the beef with the salt and black pepper. Freeze the beef for 1 hour before grinding.
2. With the Meat Grinder Housing attached to the Pasta & Beyond, press the Power Button and then the Forward Button. Grind the cheese, then the mushrooms, and finally the meat.
3. In a bowl, combine the meat, cheese, mushrooms, shallot, and steak sauce. Form the mixture into six patties.
4. On the stove top, pan sear the patties on each side until the desired doneness is reached.
5. Serving suggestion: Serve on a salad or between brioche rolls.

NOTE: Freeze meat to keep firm and cold during grinding. Do not let meat get hard.



Vegetable Burgers

SERVES 6

INGREDIENTS

1 portobella mushroom
½ red pepper
6 asparagus
½ cup cauliflower
¼ sweet potato
1 cup cooked lentils,
cooked & completely
drained
2 cloves garlic
½ granulated onion
½ tsp. salt
¼ tsp. ground
black pepper
½ tsp. smoke paprika
1 tbsp. tomato paste
1 egg
3 tbsp. chickpea flour
¼ cup grapeseed oil,
for pan frying

DIRECTIONS

- 1.** With the Meat Grinder Housing attached to the Pasta & Beyond, press the Power Button and then the Forward Button. Grind the mushroom, pepper, asparagus, cauliflower, sweet potato, lentils, and garlic in order.
- 2.** Place in a strainer to remove as much liquid as possible. Transfer to a bowl.
- 3.** Add the onion, salt, black pepper, paprika, tomato paste, egg, and chickpea flour and mix together. Form the mixture into six patties.
- 4.** On the stove top, pan sear the patties on each side in the grapeseed oil until golden.
- 5.** Serving suggestion: Serve over greens or on a roll with condiments.

Potato Pancakes

MAKES 10

INGREDIENTS

4 medium potatoes,
cubed
½ onion, cut into 6 pieces
1 egg
1 tbsp. flour
2 tbsp. breadcrumbs
or matzah meal
½ tsp. salt
¼ tsp. ground
black pepper
vegetable oil,
for pan searing.

DIRECTIONS

- 1.** With the Meat Grinder Housing attached to the Pasta & Beyond, press the Power Button and then the Forward Button. Grind the potatoes and then the onion.
- 2.** Add the egg, flour, breadcrumbs, salt, and black pepper and mix together.
- 3.** In a large sauté pan on the stove top, heat about ½ inch vegetable oil. When the oil is hot, add about ¼ cup of the pancake mixture and fry each side until golden. Repeat until all the pancakes are made.
- 4.** Serving suggestion: Serve with applesauce and sour cream.

Salmon Burgers

SERVES 4

INGREDIENTS

1 ½ lb skinless salmon, cubed
½ tsp. salt
½ tsp. ground black pepper
1 small shallot, cut in half
2 tbsp. fresh dill
1 ½ tbsp. Dijon Mustard
olive oil, for pan frying

DIRECTIONS

1. Season the salmon with the salt and black pepper. Freeze for 1 hour before grinding.
2. With the Meat Grinder Housing attached to the Pasta & Beyond, press the Power Button and then the Forward Button. Grind the dill, shallot, and salmon in order.
3. Add the mustard and mix together. Divide the mixture into four patties.
4. On the stove top, pan sear the patties on each side in the olive oil until the desired doneness is reached.
5. Serving suggestion: Serve with a salad or vegetables or on rolls.

NOTE: Freeze meat to keep firm and cold during grinding. Do not let meat get hard.



Vegetable Hash

SERVES 6-8

INGREDIENTS

½ sweet potato,
peeled & cut into 4 sticks

5 Brussels sprouts,
halved

½ green pepper,
cut into slices

5 baby bella or
cremini mushrooms

½ small onion

1 shallot

1 clove garlic

¼ cup olive oil

2 sprigs tarragon

2 tsp. paprika

1 tsp. ground fennel

½ tsp. salt

¼ tsp. ground
black pepper

1 tbsp. smoked paprika

DIRECTIONS

- 1.** With the Meat Grinder Housing attached to the Pasta & Beyond, press the Power Button and then the Forward Button. Grind the potato, green pepper, mushrooms, onion, shallot, garlic, and Brussels sprouts in order.
- 2.** Add the rest of the ingredients and mix together.
- 3.** On a griddle on the stove top, cook the hash until browned.

Corned Beef Hash

SERVES 6-8

INGREDIENTS

24 oz corned beef, cooked
½ onion, cut into chunks
½ red pepper
3 medium potatoes
½ tsp. ground coriander
½ tsp. ground cumin
¼ tsp. salt
½ tsp. ground black pepper

DIRECTIONS

1. With the Meat Grinder Housing attached to the Pasta & Beyond, press the Power Button and then the Forward Button. Grind the corned beef, onion, red pepper, and potatoes in order.
2. Add the rest of the ingredients and mix together.
3. On a griddle on the stove top, cook the hash until browned.
4. Serving suggestion: Serve with eggs.

NOTE: Freeze meat to keep firm and cold during grinding. Do not let meat get hard.

Fennel Sausage

SERVES 6

INGREDIENTS

2 lb pork butt, cubed
¾ tbsp. salt
2 tbsp. fennel seeds
1 tsp. ground black pepper
¼ cup red wine
2 cloves garlic
1 tbsp. paprika

DIRECTIONS

1. In a bowl, combine all the ingredients. Freeze for 1 hour before grinding.
2. With the Meat Grinder Housing attached to the Pasta & Beyond, press the Power Button and then the Forward Button. Grind the meat.
3. Serving suggestion: Serve with pasta dishes.

NOTE: Freeze meat to keep firm and cold during grinding. Do not let meat get hard.

Ground Chicken Chili

SERVES 4

INGREDIENTS

1 1 ½-lb chicken, breast trimmed
2 tbsp. olive oil
1 small onion, minced
½ yellow pepper, diced small
14 oz kidney beans
28 oz diced tomatoes
2 cups chicken stock
2 tbsp. chili powder
½ tsp. cumin
1 tsp. coriander
½ tbsp. salt, plus more to taste
½ tbsp. sugar
ground black pepper, to taste

DIRECTIONS

1. Freeze the chicken for 1 hour before grinding.
2. With the Meat Grinder Housing attached to the Pasta & Beyond, press the Power Button and then the Forward Button. Grind the chicken.
3. In a medium-size pot on the stove top, add the oil. Add the chicken and onion and sauté until the onion is soft and the chicken is cooked.
4. Add the chili powder and sauté while stirring to incorporate for 2 minutes.
5. Add the rest of the ingredients and simmer for 1 hour.
6. When the chili is done cooking, adjust the seasoning with the salt and black pepper.

NOTE: Freeze meat to keep firm and cold during grinding. Do not let meat get hard.



PASTA & BEYOND™

MEAT GRINDER RECIPES



Invite
celebrated chef
EMERIL LAGASSE
into your kitchen



For parts, recipes, accessories,
and everything Emeril Everyday,
go to tristarcares.com or
scan this QR code with your
smartphone or tablet:



© 2021 Tristar Products, Inc.
Distributed by:
Tristar Products, Inc.
Fairfield, NJ 07004
Made in China